

How the Electrical Telegraph Changed the World



JB Burke
Prescott Computer Society
Ottawa PCUG
December 10, 2025

Imagine this scenario ...



- It's **February 1825**, and **you** are away, working in **Washington, DC**
- Meanwhile your wife is back **home** in **New Haven, Connecticut**
 - *A bit over **300 miles** distant*
- In New Haven, your wife, Lucretia, becomes ill and suddenly passes away
- A letter is promptly sent to notify you of the tragedy
- ***By the time you receive it, your spouse has already been buried***
- The man working in Washington, DC was **Samual Morse**
- *On May 24, 1844, **Morse** sent his famous first telegraph message, from Washington, D.C., to Baltimore, Md.: “*What hath God wrought!*”*

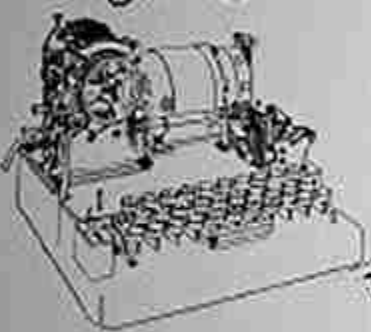
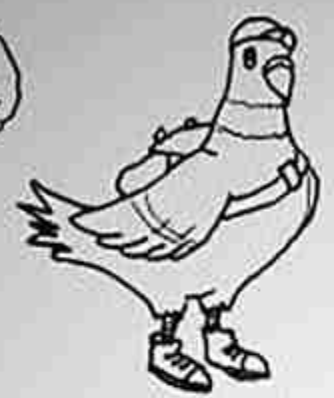

EVOLUTION OF COMMUNICATION

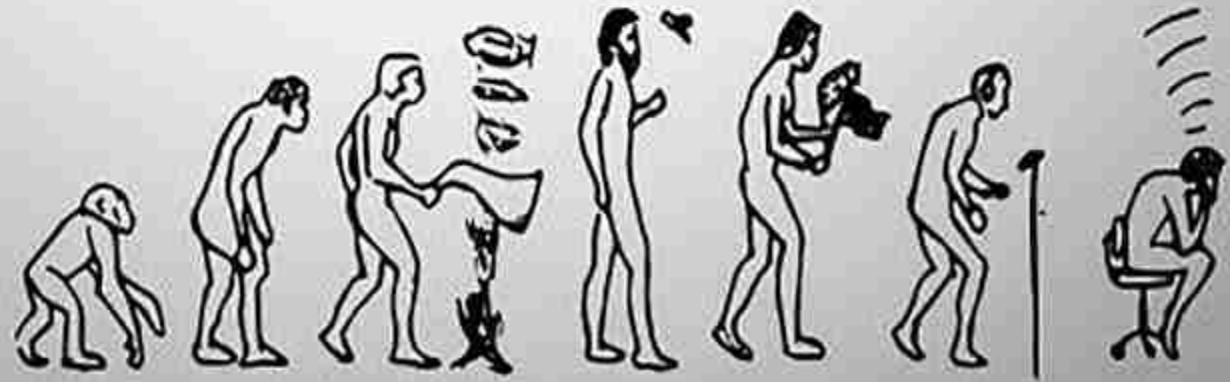
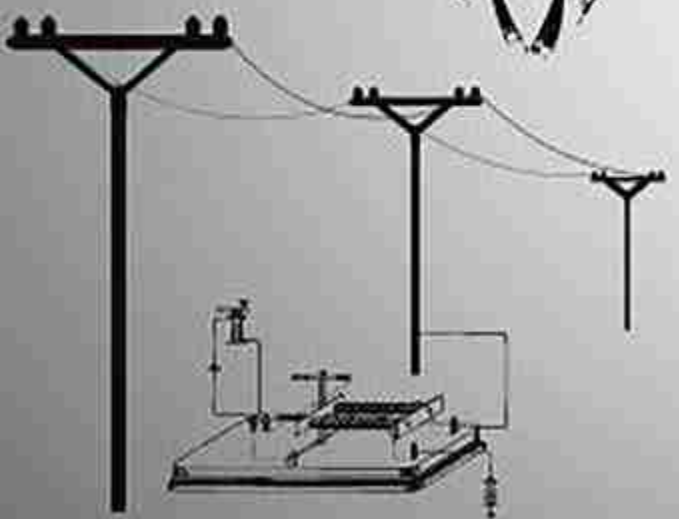

mHz
kHz



Key events in the history of communication

- **Development of speech around 100,000 BCE**
- **Invention of writing systems like cuneiform around 3500 BCE**
- **The printing press by Johannes Gutenberg in the 15th century**
- **The telegraph in the 19th century**
- **Rise of the internet in the late 20th century**

Steps in the Development of Communication?

- **First Came IMAGES, DRAWINGS, SHAPES**
 - Cave Art, Petroglyphs, Carvings, etc.
- **LANGUAGE DEVELOPED - Spoken Language**
 - Oral tradition, knowledge passed down through generations
 - Spoken messages
- **Then WRITTEN representation of language**
 - Symbols (hieroglyphics, logographs – e.g., Chinese calligraphy)
 - Alphabet (Greek, etc.)
 - History of writing systems
- **This required MEDIA FOR RECORDING**
 - Stone, ClayTablets (inconvenient to transport)
 - Papyrus, Paper
 - Scroll, Book, Tablet

How Were Messages Transmitted

- **Message Transmission**
 - **Postal Service (?)**
 - Messenger on Horseback
 - Ship
 - Carrier pigeons
 - Drums (drum telegraphy)
- **Line of Sight**
 - Smoke Signals
 - Beacon Fires
 - Semaphore
 - Optical Telegraph

What Was the Speed of Communication ...

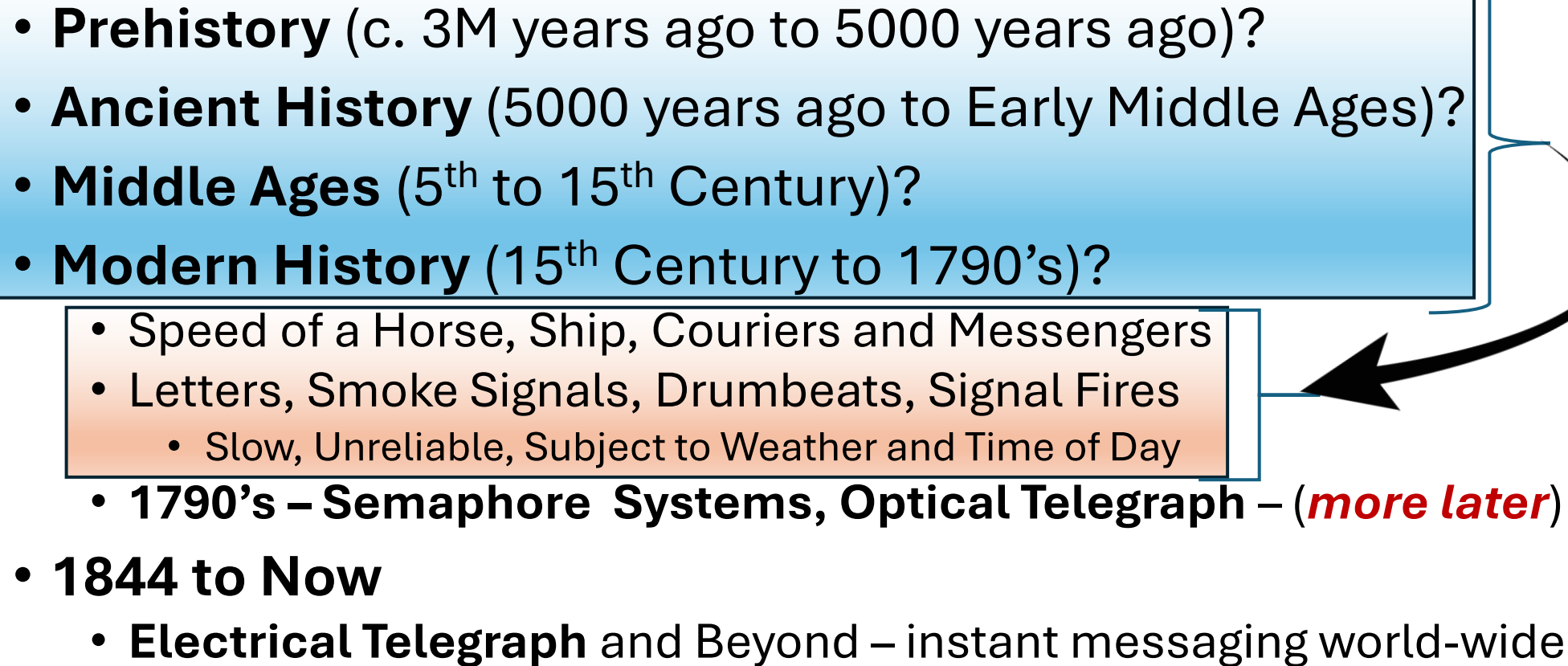
- **Prehistory** (c. 3M years ago to 5000 years ago)?
 - **Ancient History** (5000 years ago to Early Middle Ages)?
 - **Middle Ages** (5th to 15th Century)?
 - **Modern History** (15th Century to 1790's)?
 - Speed of a Horse, Ship, Couriers and Messengers
 - Letters, Smoke Signals, Drumbeats, Signal Fires
 - Slow, Unreliable, Subject to Weather and Time of Day
 - **1790's – Semaphore Systems, Optical Telegraph – (*more later*)**
 - **1844 to Now**
 - **Electrical Telegraph** and Beyond – instant messaging world-wide
- 

<https://www.historyskills.com/classroom/year-7/year-7-stone-bronze-and-iron-ages-reading/>

<https://www.havefunwithhistory.com/timeline-of-eras/>

A Major Factor in Communication Speed: How Far/Fast Can a Horse Travel?

- Horses can travel on average **30 to 50 miles a day** if they are in good condition.
- However, **top endurance horses** can travel **up to 100 miles in a day** with a rider on their back.
- Factors that determine how far a horse can travel include terrain, weather conditions, fitness, health, and the horse's breed.
- **Most horses can generally trot 20 to 40 miles a day** at an average speed of 8 mph without a problem.
 - They will need regular breaks in between running sessions to complete that distance.

What Human Activities Were Impacted by Slow Communication

- Family Life
- Politics and Elections
- Food Production and Distribution
- International Relations
- Military Activities
- Commercial Business Transactions
- Financial Transactions
- Transportation (Railways)
- Policing and Crime Fighting
- News of Current Events
- Just About **EVERYTHING!**

**The need
For speed
Was Known!**

SEEMS LIKE AN ODD QUESTION ...

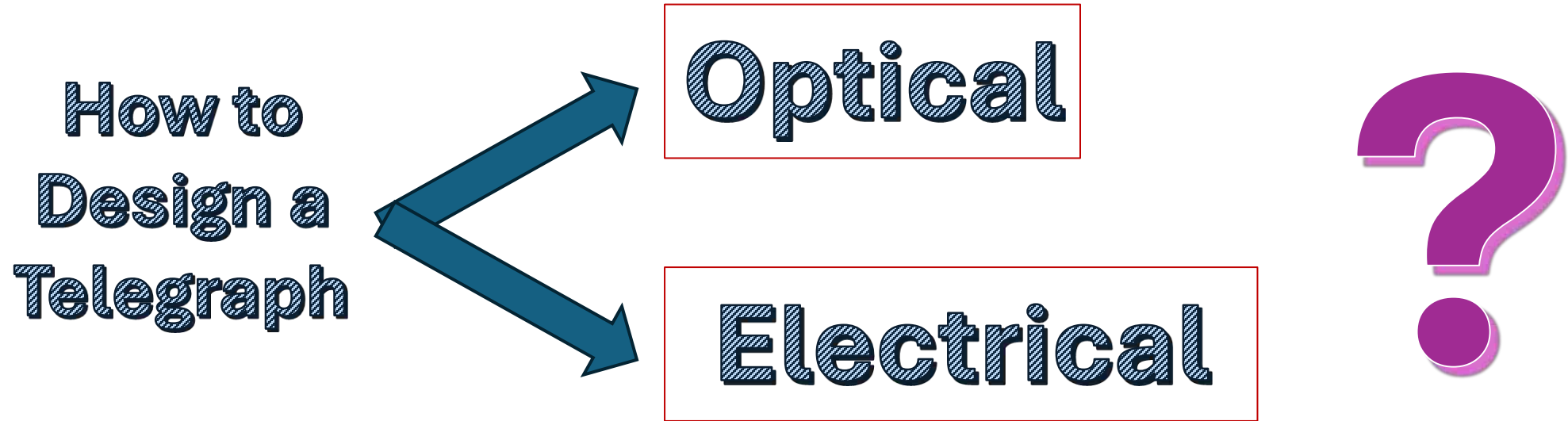

BOTH WERE DESIGNED AND BUILT!

You Couldn't Build an Electrical Telegraph Unless You Understood Electricity

- The need for faster and better communication was long known
- There were “telegraphs” before the Morse electric telegraph
- These did not rely on electricity
- **Optical/Semaphore Telegraph**
 - An optical telegraph is a line of stations, typically towers, for the purpose of conveying textual information by means of visual signals.

https://en.wikipedia.org/wiki/Optical_telegraph



What is an Optical/Semaphore Telegraph?

- **Claude Chappe** – inventor in **18th Century** France
 - Tried and failed at Electrical telegraph (**too many unknowns then**)
- Experienced a few false starts
- Began using panels painted Black/White – flipped (*semaphore*)
 - *Seen from a distance*
- **March 2, 1791**, Chappe and his brother send a message **10 miles**
 - Used **flipping panels, a telescope, a clock and a code book**
 - It took 4 minutes to send “*If you succeed, you will bask in glory*” (in French)
 - **Remember – a horse could trot about 8 MPH.**
 - He wanted to call it “**tachygraphe**” (Greek for “*fast writer*”)
 - Miot Mérito suggested “**telegraphe**” (“*far writer*”)

What is an Optical/Semaphore Telegraph?

- There were two main types of **Optical Telegraphs**;
 - The **semaphore telegraph** which uses **pivoted indicator arms** and conveys information according to the direction the indicators point, and
 - The **shutter telegraph** which uses panels that can be rotated to block or pass the light from the sky behind to convey information.

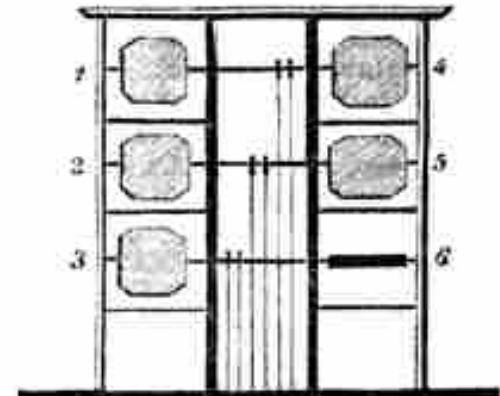
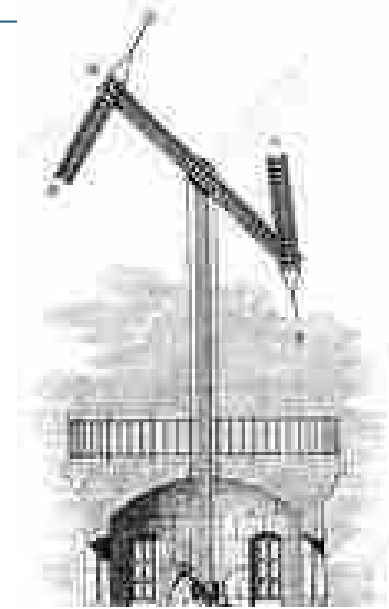

Examples of Optical/Semaphore Codes

- **Claude Chappe** invented the Semaphore Telegraph
- He continued to improve his design
 - Two small rotating arms on a longer rotating bar

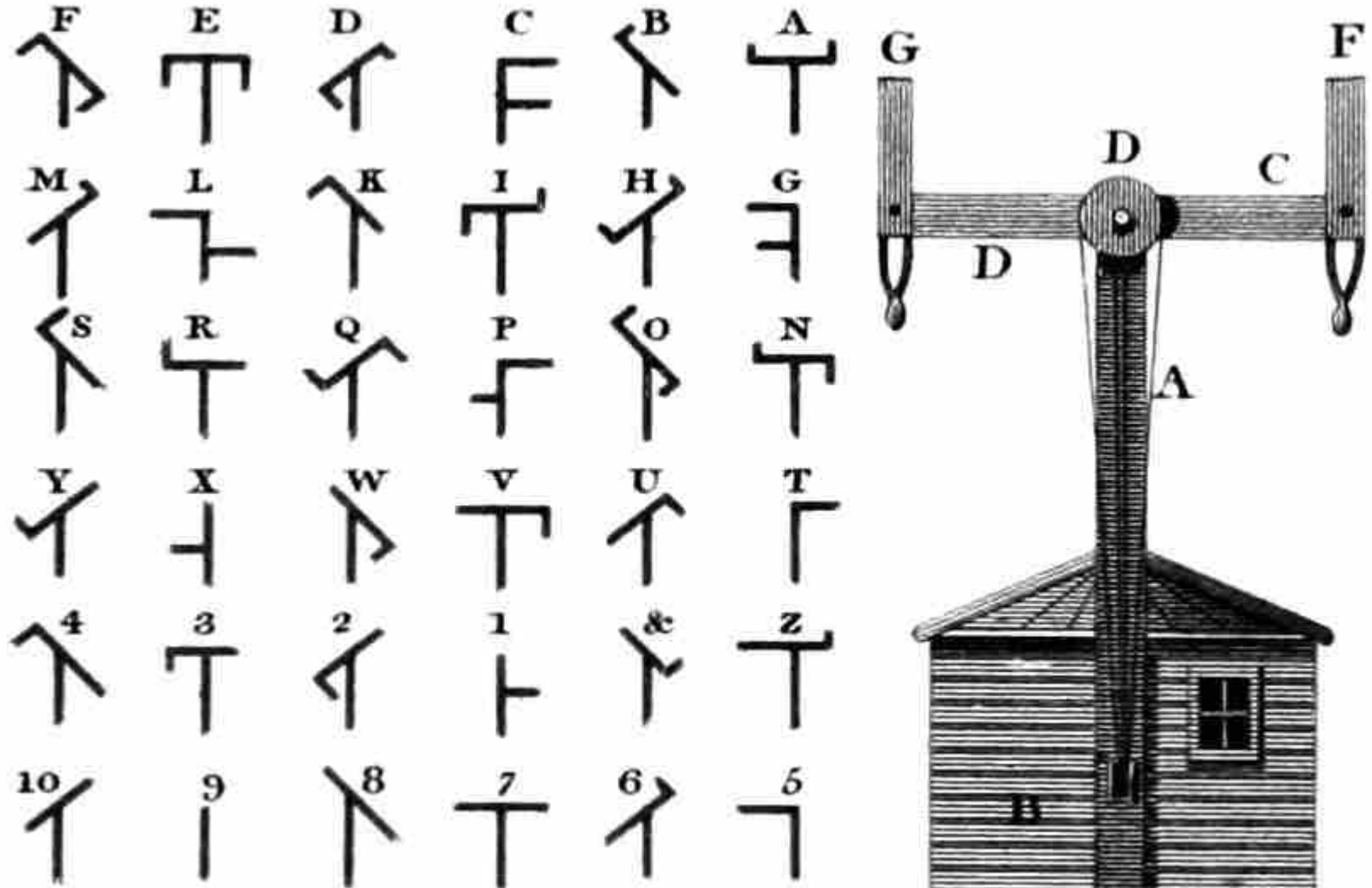

More About Optical/Semaphore Telegraph?

- It allowed for 98 different combinations
 - A code book was produced with 92 numbered pages
 - Each page had 92 numbered meanings
 - This gave a total of 8,464 words or phrases that could be sent
 - They sent the **page number**, followed by the **phrase number**
- Arms were controlled by a system of pulleys, connected to a scaled down model of the rotating arms

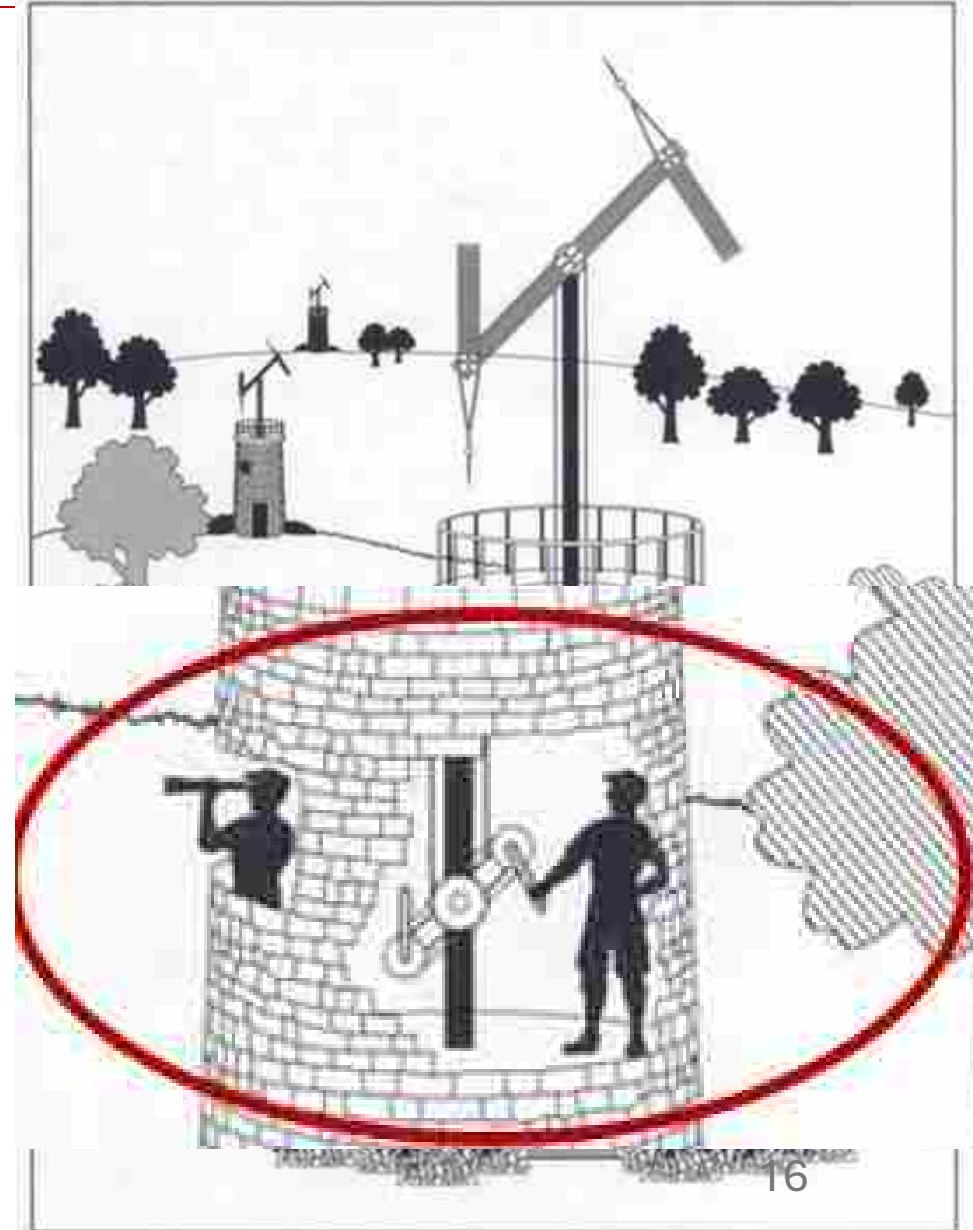
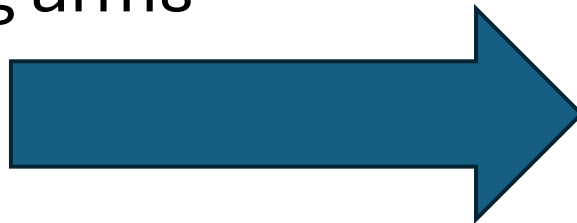

The Optical/Semaphore Telegraph in France

- In 1793 – **French Government funds** were allocated for construction of a 3-station line (~20 miles overall)
- Note: This system requires **line-of-sight** between stations
- It was demonstrated on **July 12, 1793**
- It requires **2 operators at each station**
 - One was needed to **operate the arms,**
 - The other was to **observe the next station through a telescope**
- The experiment was a success

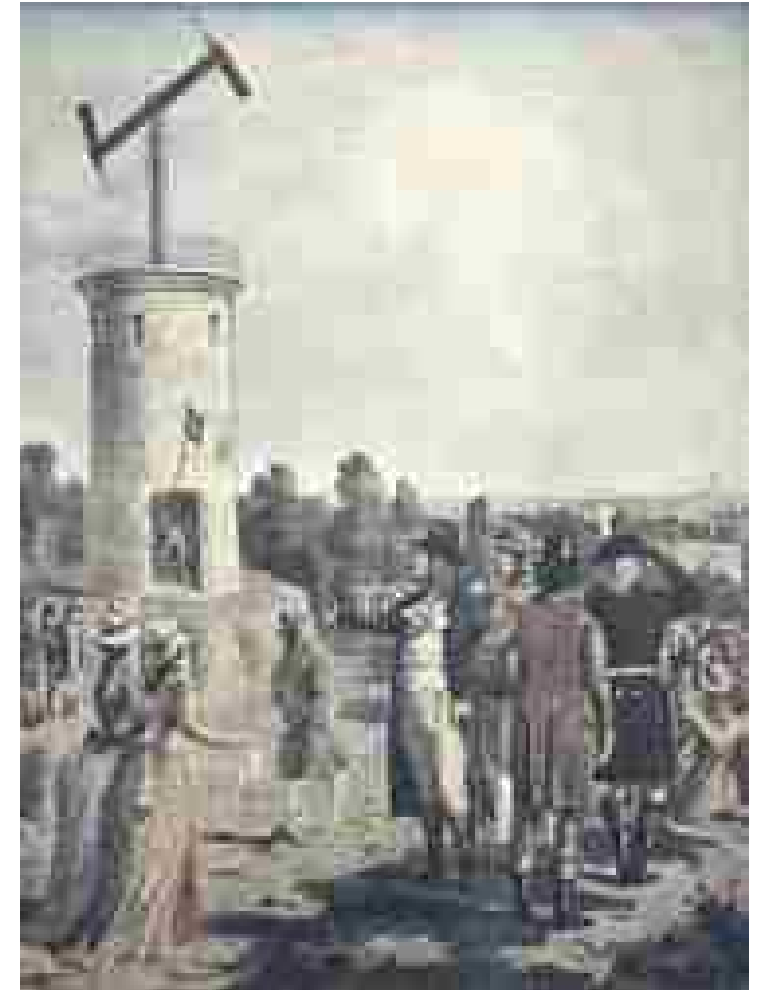

The Optical/Semaphore Telegraph Expands

- This system provided the communication needed to keep the **new French Republic** (*after the French Revolution 1789*) **together!**
- A **15-station line from Paris to Lille (130 miles)** was proposed
- Claude Chappe was put on the French government payroll
- The Paris-Lille line came online in **May 1794** – immediately useful
 - Second line Paris to Strasbourg **1798**. Lille line was extended to Dunkirk.
- Napoleon Bonaparte seized power in **1799**
 - He ordered the extension of the line to prepare for invasion of England
 - *A proposed English station never happened.*
 - He had the Paris line extended to Milan
- Sweden and England copied Chappe's design

Napoleon's Chappe Telegraph System (1811)

Each station must
Be in sight
Of two others.

534 Stations
Over 3,000 miles

<https://www.thehistoryblog.com/archives/25773>



Optical/Shutter Telegraph in England

- **George Murray** designed the **British shutter** telegraph
 - 64 possible combinations
 - $2 \times 2 \times 2 \times 2 \times 2 \times 2 = 2^6$
- These optical telegraph systems were mostly used for government messages
 - Plus (in France) weekly transmission of the **winning national lottery numbers**
- By the mid-1830's there were many lines across Europe
 - Almost **1000 Optical telegraph towers**

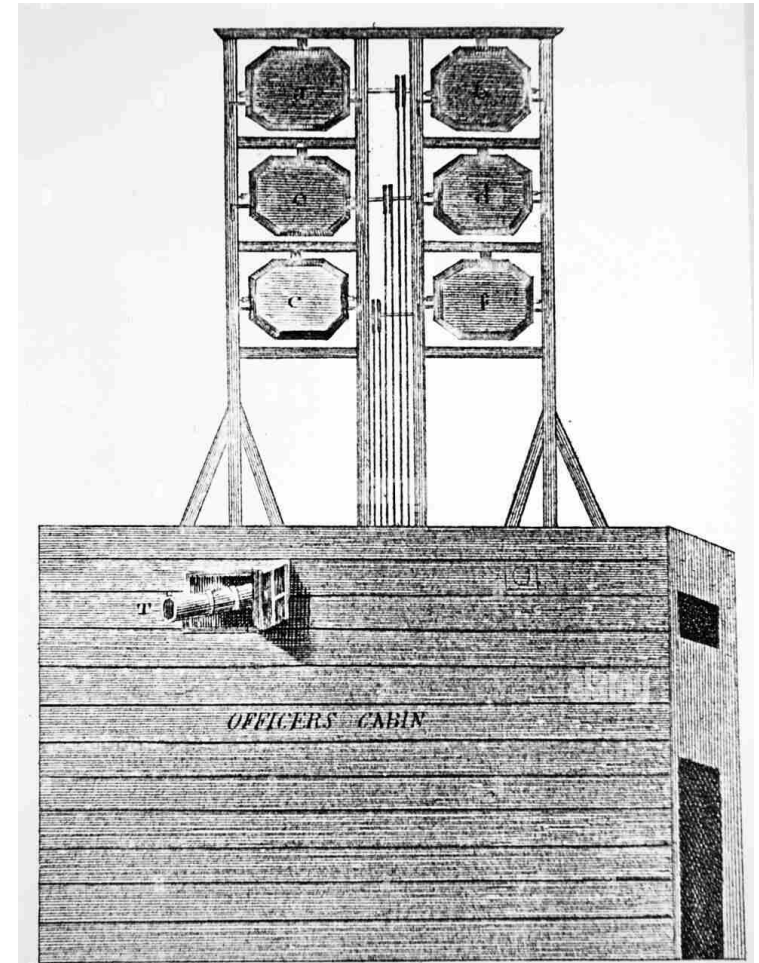

Map of the routes of the British Admiralty Shutter Telegraph.

The semaphore system that replaced it took slightly different routes.



Optical/Semaphore Telegraph Limitations

- The semaphore telegraph remained operational in France until **1852**. The last semaphore station to go out of service was in Sweden in **1880**.
- Chappe's and Murray's systems were limited
 - Expensive to operate
 - Shifts of skilled operators employed at each station
 - Required building many towers on hilltops
- **Only governments could afford to use them**
- Limited information carrying ability
- **Didn't work in the dark, fog or mist!**

Optical/Semaphore Telegraph - *Resources*

- **The Optical Telegraph: Faster than a Messenger on Horseback**
 - <https://www.historyofinformation.com/detail.php?entryid=496>
- **Telegraphy Timeline: the first 120 years**
 - <https://museumofcommunication.org.uk/telegraphy/>
- **How Napoleon's semaphore telegraph changed the world**
 - <https://www.bbc.com/news/magazine-22909590>
- **How the Telegraph Went From Semaphore to Communication Game Changer**
 - <https://www.smithsonianmag.com/arts-culture/how-the-telegraph-went-from- semaphore-to-communication-game-changer-1403433/>

What was needed to create an electrical telegraph?

1. The **technology to send an electrical signal ...**
 1. *Knowledge of how electricity worked*
2. ... across a wire (**over a long distance**)
3. ... and a way to **read or interpret the signal** at the other end

That's all!

The Electrical Telegraph

- First suggestion of electric telegraph –
 - Scott's Magazine **Feb. 17, 1753**
- **1753 to 1837 - 60+ experimental electrical telegraphs were tried**
- Development of the **Science of Electricity** was needed
 - **Remember – 200 years ago there were no electric lights, batteries, motors, no electrified homes, no electric appliances.**
 - **Electricity wasn't understood**
- On **April 21, 1820**, Hans Christian Ørsted saw that electric current flowing thru a wire created **electromagnetism**
- He found the physical law describing the magnetic field, now known as Ørsted's law. ([Wikipedia](#))
- A problem remained – **an electric signal faded over distance**

The Electrical Telegraph – Lost Opportunities

- **1826-27:** Harrison Gray Dyar successfully experiments with electrical telegraphy but abandons the pursuit.
- **1836:** [David Alter](#) of [Pennsylvania](#) develops a working electrical telegraph system but never develops the idea into a practical system.

The Electrical Telegraph

- In **1832** Morse caught *the telegraph* bug on a trans-Atlantic voyage
 - He overheard another passenger's conversation
 - Morse had experienced the sorrow of delayed communication
- But Morse **underestimated** the electric problem, so he started work on a **signaling code**
 - He considered **long and short bursts of current**
 - He thought of sending numbers to correspond to a code book

Scientific Advancements Required Before the Electrical Telegraph Could Exist

- The Italian [Alexander Volta](#) (1745-1827) invented the **electric battery** in 1800, necessary for a telegraph machine to be operated anywhere.
- Danish physicist Hans Christian Ørsted (1777-1851) created the first **electromagnet** in 1825.
 - Crucial to the telegraph machine since this was the answer to the problem of **how to make electrical impulses visible in the form of a moving needle. (Receiver)**
- French physicist André-Marie Ampère (1775-1836) worked to create **a theory that explained the relationship between an electrical current and magnetism.**

https://www.worldhistory.org/Electrical_Telegraph/

Scientific Developments as Pre-requisites to the Electrical Telegraph

- The **first electric motor** was developed by the Englishman Michael Faraday (1791-1867) in **1821**.
- With all these scientific discoveries put together, inventors now had the theoretical means to **send electrical impulses through a wire and then see the effect at the other end**.
- The trick was just how to **create a working machine** capable of sending and receiving these impulses over long distances and a **code by which such impulses could be transformed into words**.

https://www.worldhistory.org/Electrical_Telegraph/

The First Electrical Telegraph

- The first commercial telegraph machine was invented by two **Englishmen** working together: **William Fothergill Cook** and **Charles Wheatstone**.
- The first version of their telegraph, patented in **1837**, had **20 letters** on a diamond-shaped board with five needles and six wires.
- The six letters of the alphabet missing were simply omitted from messages. (**C, J, Q, U, X** and **Z** omitted, and **no punctuation**)
- The message received by the machine was indicated by the slight movement of any two of the needles to the left or right.

Cooke's & Wheatstone's Telegraph Relied on the Galvanometer.

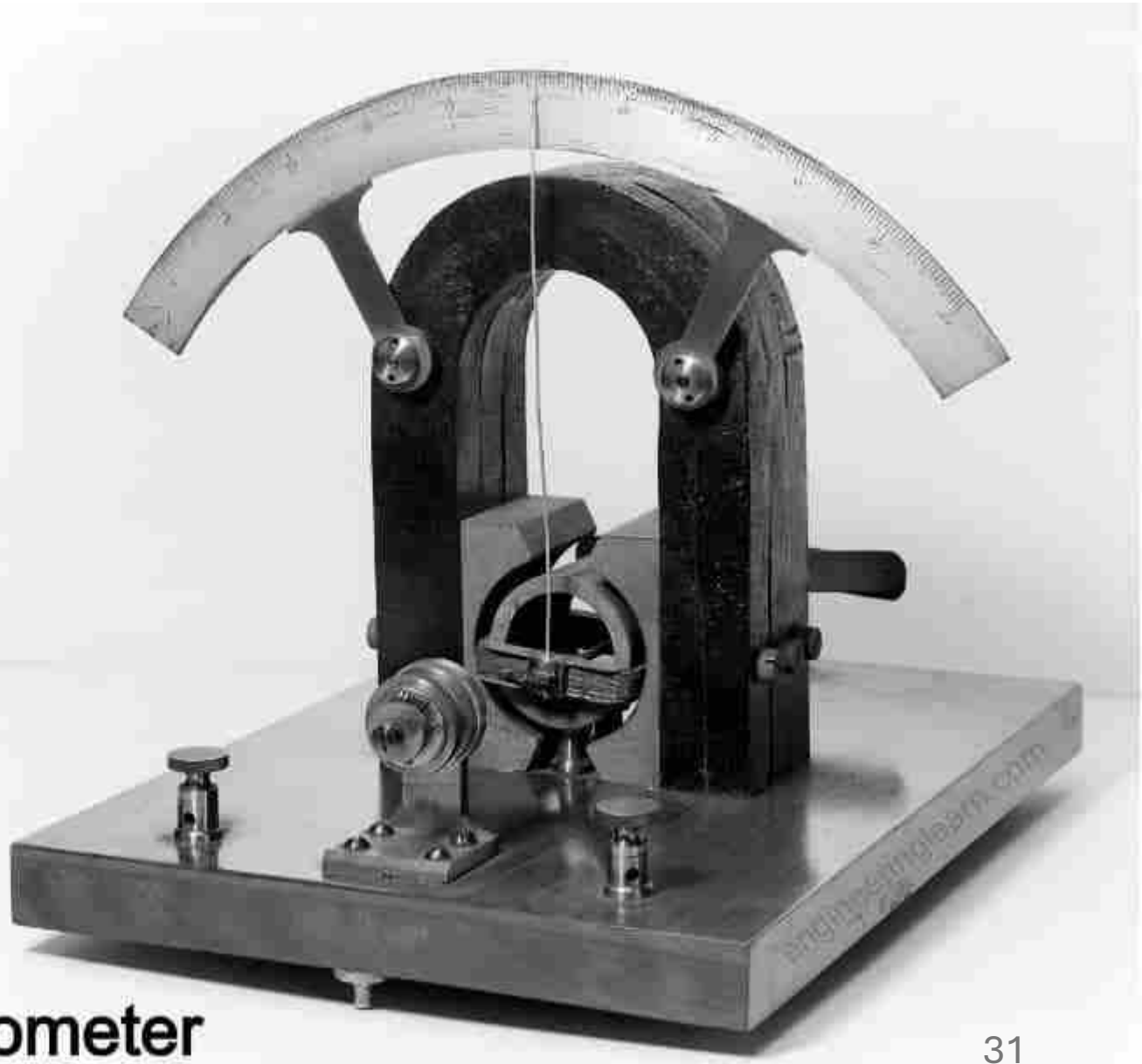
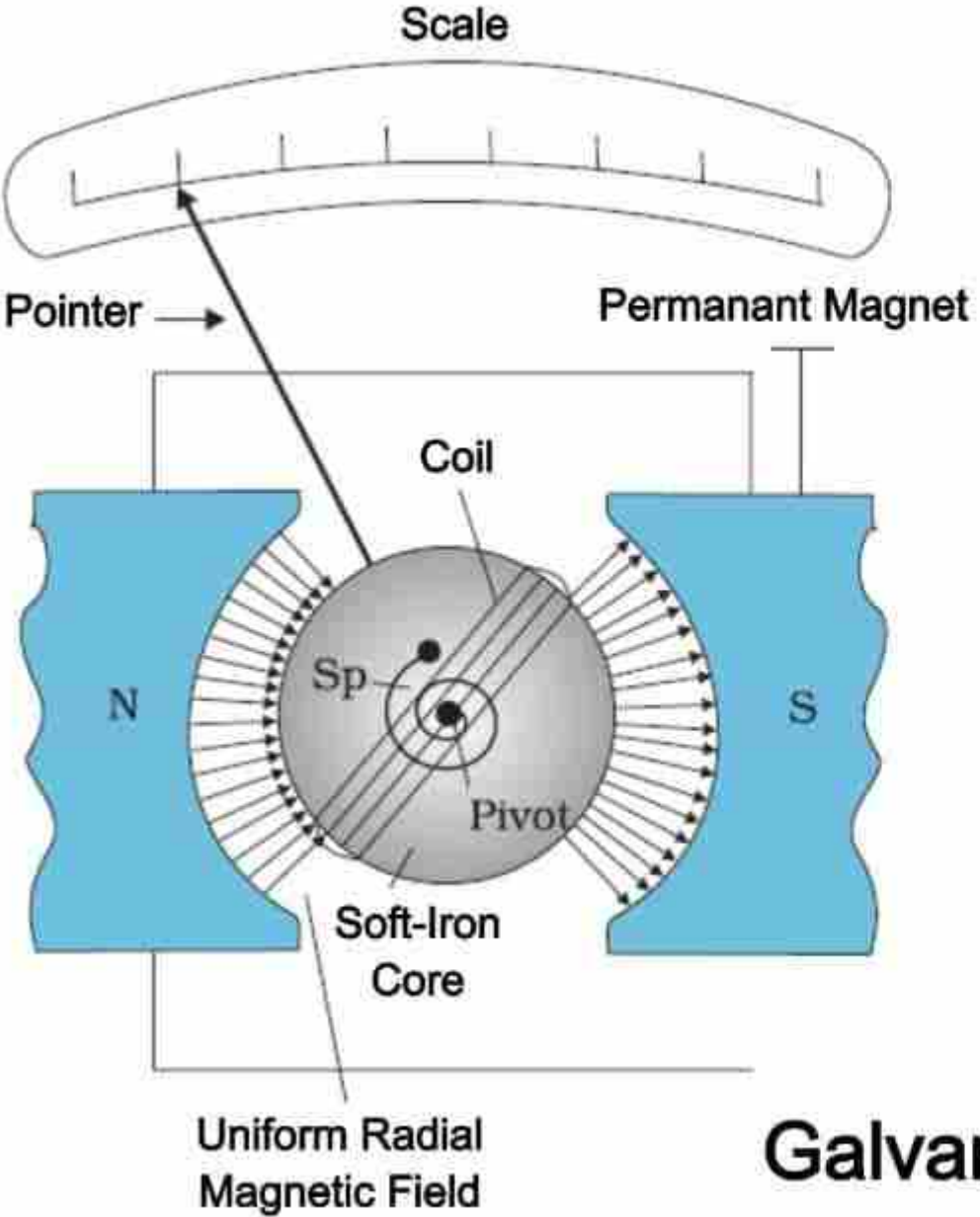

Galvanometer

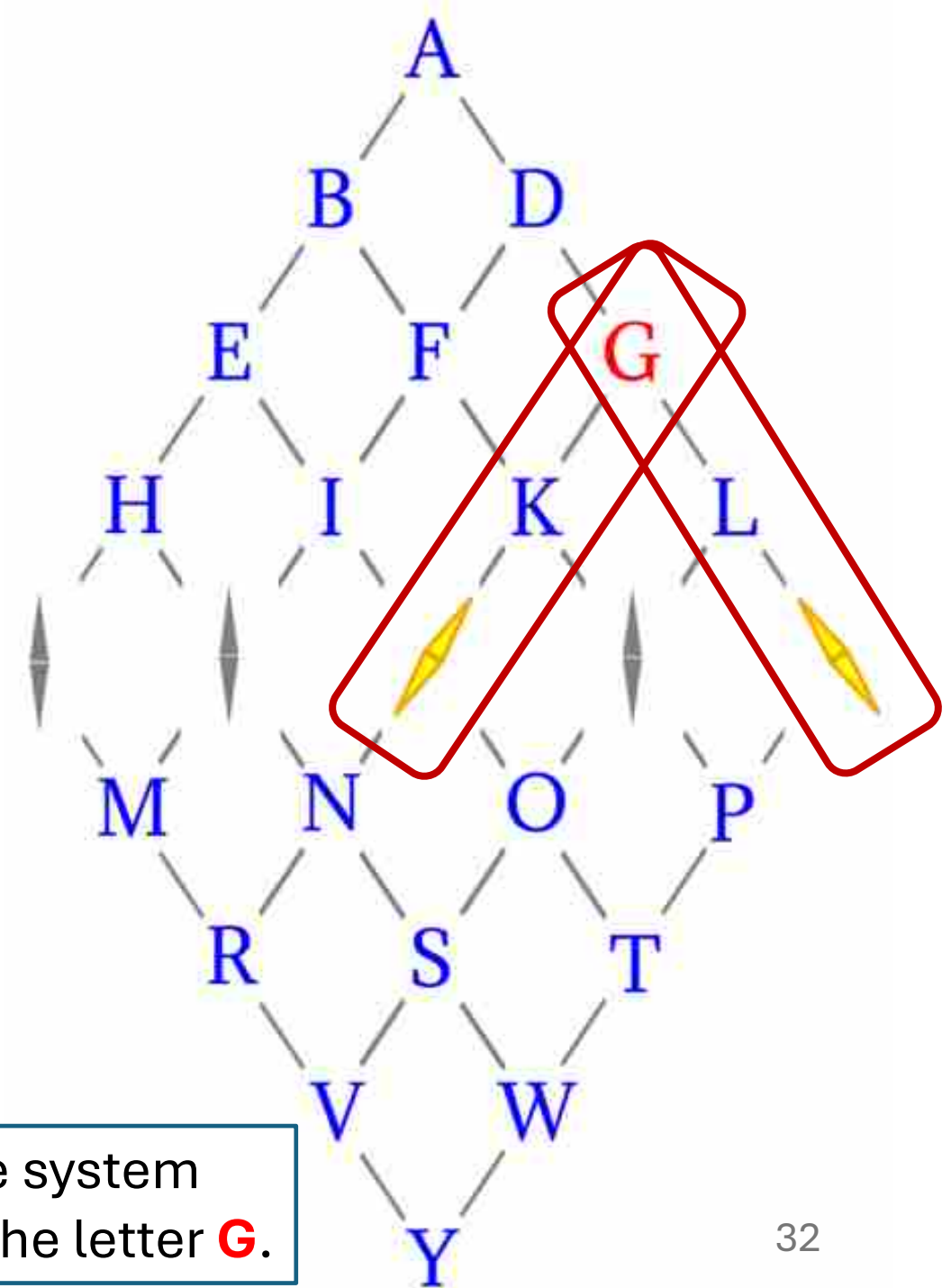

Five needle system
Receiving the letter **G**.

The First Electrical Telegraph

- The first successful commercial use of the machine was for the **Great Western Railway** in 1838, used between two stations, a distance of **13 miles**.
- Short messages could be sent quickly and were first used on the railways to **communicate instructions to drivers and stations**.
- The machine was quickly adopted by other railway companies at home and abroad, including by the British East India Company from 1851.
- In 1867, the first machine to indicate numbers as well as letters was used.

Cook & Wheatstone Telegraph Had Some Commercial Success

- There were multiple versions proposed
 - A four-needle system was installed in 1837
- The five-needle system required 6 wires
 - It was installed in 1838
 - The letters could be read directly off the device
 - **Wires were run underground in a lead pipe – that soon began to fail**
 - A one-needle, 2-wire system was devised using the remaining wires
 - This was the first time in telegraph history that skilled telegraph operators were required
- This system proliferated throughout England



**Still didn't
Understand
Electricity**

Cook & Wheatstone Telegraph Had Some Commercial Success (And Fought Crime)

- Cooke and Wheatstone helped in early instances of “modern” crime fighting.
- Murder suspect [John Tawell](#) was apprehended following the use of a needle telegraph message from [Slough to Paddington Station in London](#) on **1 January 1845**.
- A MURDER HAS **G**UST BEEN KOMMITTED AT SALT HILL AND THE SUSPECTED MURDERER WAS SEEN TO TAKE A FIRST CLASS TICKET TO LONDON BY THE TRAIN WHICH LEFT SLOUGH AT 742 PM HE IS IN THE GARB OF A **KW**AKER WITH A GREAT COAT ON WHICH REACHES NEARLY DOWN TO HIS FEET HE IS IN THE LAST COMPARTMENT OF THE SECOND CLASS COMPARTMENT

The **version** of the Cooke-Wheatstone telegraph they were using could not send the letters **J, Q, and Z** nor **Punctuation**.

COOKE AND WHEATSTONE'S TELEGRAPH

Resources

- **The Victorian Internet PDF**
 - <https://cdn.bookey.app/files/pdf/book/en/the-victorian-internet.pdf>
- **Cooke and Wheatstone telegraph**
 - https://en.wikipedia.org/wiki/Cooke_and_Wheatstone_telegraph
- **A tale of two telegraphs: Cooke and Wheatstone's differing visions of electric telegraphy**
 - <https://journal.sciencemuseum.ac.uk/article/cooke-and-wheatstones/#abstract>

Joseph Henry's Contribution

- Joseph Henry had solved the signal distance problem **between 1829 and 1830**.
- By using an **electromagnet**, plus **many small batteries** in a row a signal could be sent farther.
- **But ... neither Morse nor Cooke knew this.**
- Meanwhile, Morse spent time developing a complicated telegraph device
- **1835** - Morse teamed up with Professor Leonard Gale and Alfred Vail
- They simplified down to a **tapping key**, and **pen that inscribed dots and dashes**, and **full alphabet of codes**, *tuned to letter frequency*.

MORSE CODE ALPHABET

A ···	J ·····	S ...
B ····	K ····	T -
C ····	L ····	U ····
D ····	M -	V ····
E ·	N -·	W ····
F ····	O -	X ····
G -·	P ····	Y ····
H ····	Q ····	Z ····
I ··	R ····	

And Just
For Fun!

Morse Code Receive Decoder Chart (a-z)

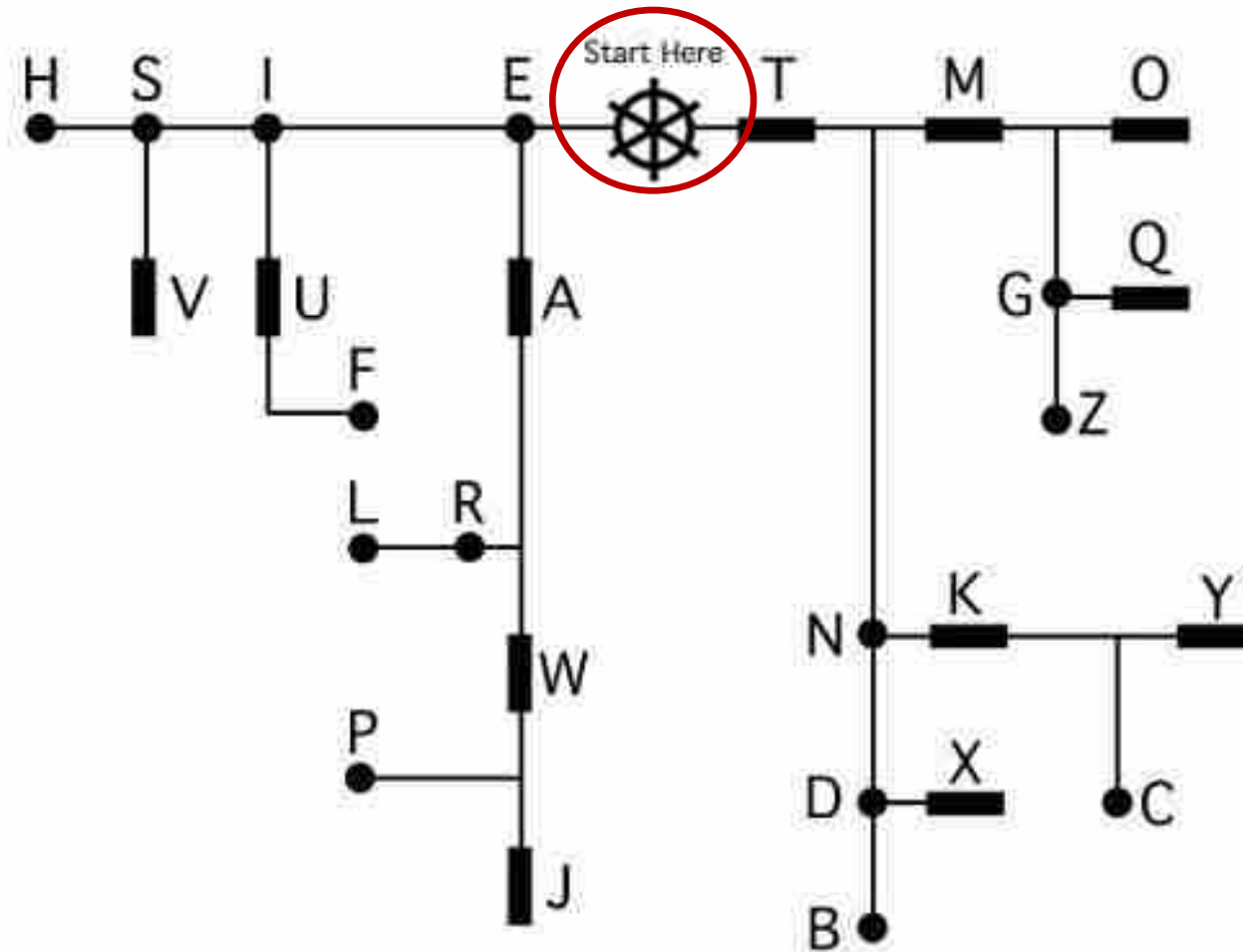

© Dave Nathanson KG6ZJO copyleft 2010 all wrongs reserved

Morse, & Vail

- **Morse** foresaw world-wide communication via telegraph
- But the electrical telegraph was **hard for most people to envision** – skeptics abounded.
- There was a **need to demonstrate** a large working systems.
 - *It had been **proposed in Congress to build a Chappe-style Semaphore telegraph** from Washington DC to New Orleans.*
- In **1838** Morse showed his **Electrical Telegraph** to Congress.
 - His demo was between 2 stations close together **but with a large coil of wire in between to represent distance.**
 - They didn't understand it and **rejected his request for funding.**
- Morse went to Europe – 1838 to 1839 – to popularize his design
- **June 20, 1840** – Morse obtains **patent** for Telegraph

The Patent that Led to the Creation of Morse Code (June 20, 1840)

<https://suiter.com/patent-history-electric-telegraph-morse-code/>

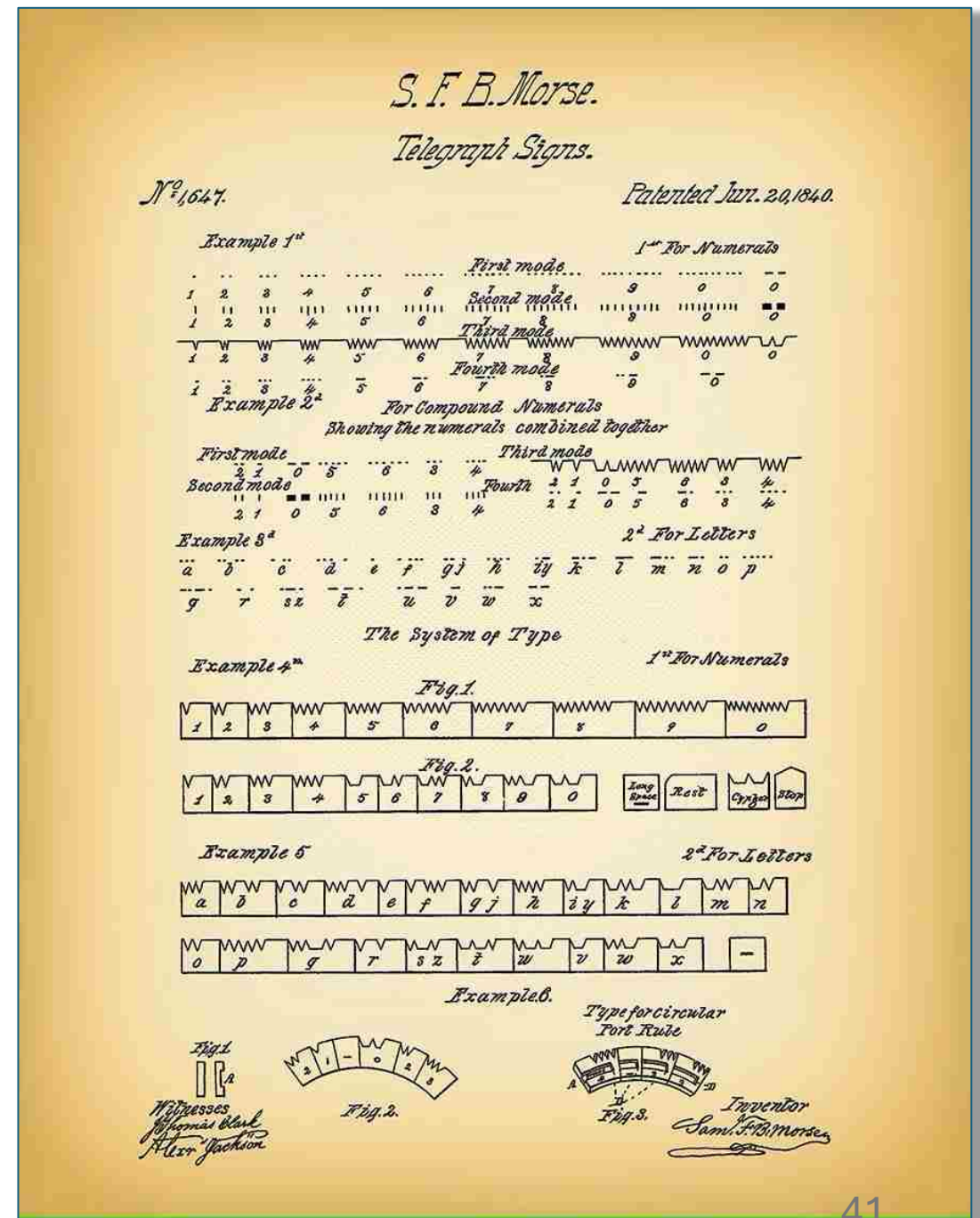

Morse Back to Congress

- **March 3, 1843**, Morse did another demo and now got **\$30,000** from Congress for an experimental line.
- Some in Congress thought it was not real.
 - Rep. Cave Johnson of Tennessee thought Congress might as well fund research into mesmerism.
- The funding passed by **89 to 83 votes**.
- Morse built a line from **DC to Baltimore along B&O Line**.
- Congress appointed John W. Kirk to be **an observer of “crazy” Morse**.
 - His telegraph idea was considered by many in Congress as **“impractical or crazy”** and mere **“foolishness”**

Proving the Telegraph Really Worked!

- Observer Kirk produced **a scheme to verify Morse' system.**
 - **The Whig convention** was scheduled shortly for Baltimore
 - The **DC** telegraph line was then within 15 miles of Baltimore
 - **May 1, 1844 - By successfully transmitting the names of the convention nominees, Morse could prove the usefulness of his invention**
- The nominee names were transmitted from the telegraph line's terminus (at a RR station near Baltimore) to DC
- **The names were announced in DC 64 minutes before they "officially" arrived by train from Baltimore.**
- Even the most skeptical were convinced

What the Heck is a Telegraph?

- The line was completed from **DC to Baltimore on May 24, 1844.**
- Morse transmitted his famous “**What hath god wrought**” message.
- But the electrical telegraph was **still not taken seriously by many**
- Meanwhile, in England, Cooke was also facing similar challenges
 - He used his telegraph to announce **the birth of Queen Victoria’s son on November 9, 1841**
 - The Duke of Wellington used it to request his **left-behind suit** be forwarded by train for a formal occasion of state

Private Enterprise Was the Way to Go!

- **Morse went back to Congress** to request funding to extend his line from Baltimore to New York
 - He advocated for more cities to connect
 - **They turned him down *again***
- Morse went to **private investors**
- **April 1, 1845** – the Postmaster General imposed a tariff on messages
- In **May 1845**, the **Magnetic Telegraph Company** was formed
 - **Multiple lines were now under construction**
- The business was built out slowly
 - **January 1846** – line opened **between New York and Philadelphia**
- Meanwhile, in England, Cooke and new partner Ricardo created the **Electrical Telegraph Co.**

More Progress

- The first commercial telegraph line in the US was opened in **1844**.
- In **1845**, Morse oversaw the building of the first telegraph line linking the East Coast with the Midwest.
- Commercial use of the telegraph rapidly became essential for businesses to remain competitive

Explosive Growth of the Telegraph!

- In **1852** – Scientific American reported, “**No invention of modern times has extended its influence so rapidly as that of the electric telegraph**”.
 - 1846 – the **40-mile** experiment
 - 1848 – **2,000 miles** of line
 - 1850 – **12,000 miles** of line
- By **1852**:
 - Eleven lines extended out of New York
 - **23,000 miles of line in operation**
 - **10,000 miles under construction**



Up, up and away!

Cariff of Rates by the National Telegraph Lines,

FROM PITTSBURGH, PA.

TO ALL PARTS OF THE UNITED STATES AND THE CANADAS.

Office, South East corner of Wood and Third Streets.

Pittsburgh to	Charge per 100 lbs.	No. of wks.	Pittsburgh to	Charge per 100 lbs.	No. of wks.	Pittsburgh to	Charge per 100 lbs.	No. of wks.	Pittsburgh to	Charge per 100 lbs.	No. of wks.
A			E			M & Mc			S		
Alexandria, Va.	56	5	Evansville, Ia.	1 00	7	Liverpool, N. S.	2 85	17	Rochester, "	25	2
Albany, N. Y.	1 00	8	Eugene, "	80	5	Lanenburg, "	2 72	16	Richmond, Va.	67	5
Auburn, "	75	6	Elkhart, "	1 00	6	Lamberville, N. J.	60	5	Raleigh, N. C.	84	6
Amsterdam, "	87	7	Eric, Pa.	40	3	Little Falls, N. B.	2 65	17	Rushville, Ill.	1 20	6
Ansable Forks, "	1 40	11	Easton, "	60	5				Rock Island, "	1 30	8
Avon, "	95	7	Elyria, O.	40	3				Rockford, "	1 05	5
Ann Arbor, Mich.	75	6	Easton, "	60	5				Rockton, "	1 05	5
Adrian, "	75	6	Elgin, Ill.	1 00	8	Mt. Carbon, Pa.	65	5	Ripley, O.	40	3
Algonac, "	80	6	Eastport, Miss.	1 25	8	Meadville, "	25	2	Republic, "	45	3
Albion, "	75	6	Elmyra, N. Y.	1 00	8	Montrose, "	1 10	9	Ravenna, "	25	2
Alton, Ill.	1 30	8	Elizabethtown, "	1 37	11	Mauch Chunk, Pa.	65	5	Roscoe, "	50	4
Aurora, "	1 00	7	Earlville, "	1 07	9	Milton, "	49	3	Richmond, Ia.	60	5
Attica, Ind.	80	5	Ellsworth, Me.	1 85	11	Muncy, "	50	2	Rising Sun, "	60	5
Aurora, "	60	5	East Thomaston, "	1 40	9	M'EWENSBURG, "	76	5	Racine, W. T.	1 00	8
Athens, O.	35	2	East Machetas, "	1 40	9	Milesburg, "	58	3	Rome, N. Y.	87	7
Akron, "	25	2	Eastport, "	2 00	12	M'EWENSVILLE, "	51	3	Rochester, "	75	6
Ashland, "	50	4	Enfield, N. H.	1 15	9	Montourville, "	80	6	Rondont, "	1 00	8
Appleton, Wis.	1 60	9	Essex, Vt.	1 30	9	Mill Hall, "	56	3	Rutland, Vt.	1 25	10
Atlanta, Ga.	1 91	12	Eddyville, Ky.	1 05	9	Midlinton, "	30	2	Ripley, Miss.	1 10	8
Augusta, "	1 13	9	F			M'Kee's Falls, "	44	3	River Trent, C. W.	94	7
Arrow Rock, Mo.	1 20	9	Fredericksburg, Va.	61	5	Macon, Ga.	1 66	10	River De Loup, L. C.	2 90	18
Allentown, Pa.	60	6	Farmville, "	22	7	Montgomery, Ala.	1 85	11	Randolph, Mass.	1 10	8
Altoona, "	30	2	Fayetteville, N. C.	90	7	Mobile, "	2 07	12	Rockland, Me.	1 80	11
Amherst, N. S.	2 45	15	Fort Plaine, N. Y.	90	7	Millford, Del.	75	6	Richmond, "	1 80	11
Augusta, Me.	1 80	11	Frederonia, "	50	4	Morris, Ill.	1 05	5	Richbucts, N. B.	2 40	11
Antagonish, N. S.	2 72	16	Fort Edwards, "	1 30	10	Mt. Sterling, "	1 10	7			
Amherst, "	2 05	14	Fonda, "	87	7	Merango, "	1 05	5			
Annapolis, "	2 85	18	Fulton, "	1 07	9	Mt. Carroll, "	1 20	6			
						Marietta, O.	30	2	Sharon, Pa.	25	2
						Massillon, "	25	2	Sunbury, "	49	3
						Milan, "	55	4	Seelin's Grove, "	45	3
						Maumee City, "	60	4	Shippensburg, "	30	2

The Transcontinental Telegraph Line

- Construction on the line was the work of Western Union, which Hiram Sibley, Jeptha Wade, and Ezra Cornell had **established in 1856** by merging companies operating east of the Mississippi River.
- A second significant step was the passing of the Telegraph Act by the Congress in 1860, which authorized the government to open bids for the construction of a telegraph line between Missouri and California and regulated the service to be provided.
- Eventually, the only bidder would be Sibley, because all competitors—Theodore Adams, Benjamin Ficklin and John Harmon—withdrawed at the last minute. *Later they rejoined Sibley in his effort.*

Listen to this!

**Radio dramatization “Wire to the West”
August 30, 1949 – Raymond Massey**

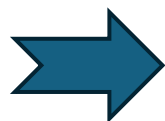

<https://www.oldtimeradiodownloads.com/drama/the-cavalcade-of-america/wire-to-the-west-1949-08-30>⁵⁰

The Transcontinental Telegraph Line

- At completion in October 1861, they had planted **27,500 poles** holding **2,000 miles of single-strand iron wire** over a terrain that was not always inviting
- Keeping it in operation faced multiple problems:
 - (a) **inclement weather** in the form of lightning bolts, strong winds, and heavy snow damaged both poles and the wire;
 - (b) **rubbing on the poles by bison** from time to time sent down sections of the telegraph, eventually contributing to their demise;
 - (c) the system had to be **rerouted through Chicago to avoid Confederate attempts to cut the line in Missouri** to disrupt communications among Union forces;
 - (d) **Native Americans** soon started to do the same farther west as part of their hostilities with the Army.

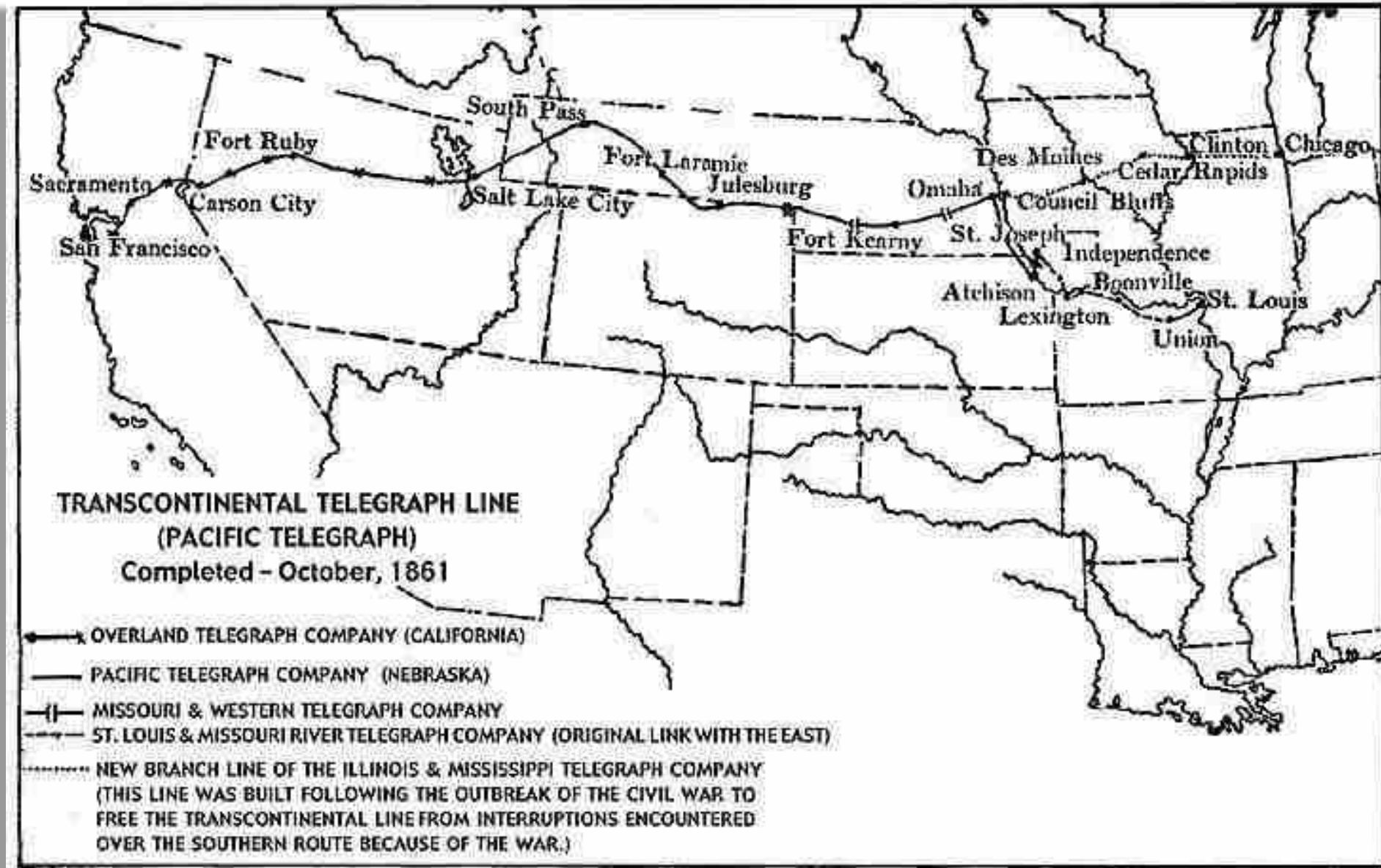

“When the Telegraph Came to California”
<https://www.telegraph-history.org/california/>

The Pony Express

- The telegraph quickly **shut down the Pony Express**
 - Pony Express took about 10 days to go 1800 miles
- The Pony Express was put together in two months in the winter of 1860.
- The roughly 186 Pony Express stations were about 10 to 15 miles apart along the Pony Express route.
- At each station, the express rider would change to a fresh horse, get a bite to eat, and would only take the **mail pouch called a *mochila*** (from the Spanish for pouch or backpack) with him.
- Despite a heavy subsidy, the Pony Express was not a financial success and **went bankrupt in 18 months**

https://en.wikipedia.org/wiki/Pony_Express

PONY EXPRESS!

CHANGE OF TIME!  REDUCED RATES!

10 Days to San Francisco!

LETTERS

WILL BE RECEIVED AT THE
OFFICE, 84 BROADWAY,
NEW YORK,
Up to 4 P. M. every TUESDAY,
AND
Up to 2½ P. M. every SATURDAY,
Which will be forwarded to connect with the PONY EXPRESS leaving
ST. JOSEPH, Missouri,
Every WEDNESDAY and SATURDAY at 11 P. M.

TELEGRAMS

Sent to Fort Kearney on the mornings of MONDAY and FRIDAY, will connect with PONY leaving St. Joseph, WEDNESDAYS and SATURDAYS.

EXPRESS CHARGES.

LETTERS weighing half ounce or under..... \$1 00
For every additional half ounce or fraction of an ounce 1 00
In all cases to be enclosed in 10 cent Government Stamped Envelopes,
And all Express CHARGES Pre-paid.

PONY EXPRESS ENVELOPES For Sale at our Office,
WELLS, FARGO & CO., Ag'ts.
New York, July 1, 1861.

SOLE & JAMES STADONER AND PRINTERS, 30 CULTON STREET, NEW YORK

The Pony Express

- The *mochila* could hold 20 pounds of mail plus the 20 pounds of material carried on the horse. Eventually, everything except one revolver and a water sack was removed, allowing for a total of **165 pounds** on the horse's back.
- **Riders, who could not weigh over 125 pounds**, changed about every 75–100 miles, and rode day and night.
- In emergencies, a given rider might ride two stages back-to-back, over **20 hours on a quickly moving horse**.

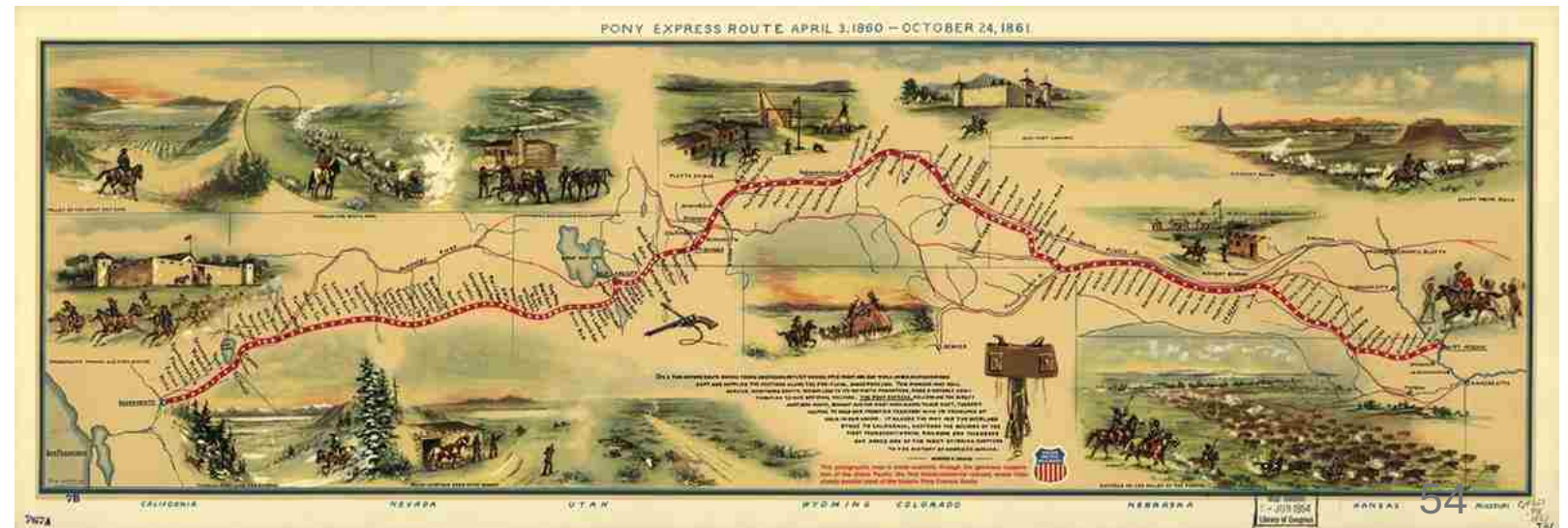

The Transcontinental Telegraph

<https://www.nps.gov/articles/000/the-transcontinental-telegraph.htm>

Digital Map Provides Interactive Lesson on Telegraph History

<https://telegraph.library.cmu.edu/>

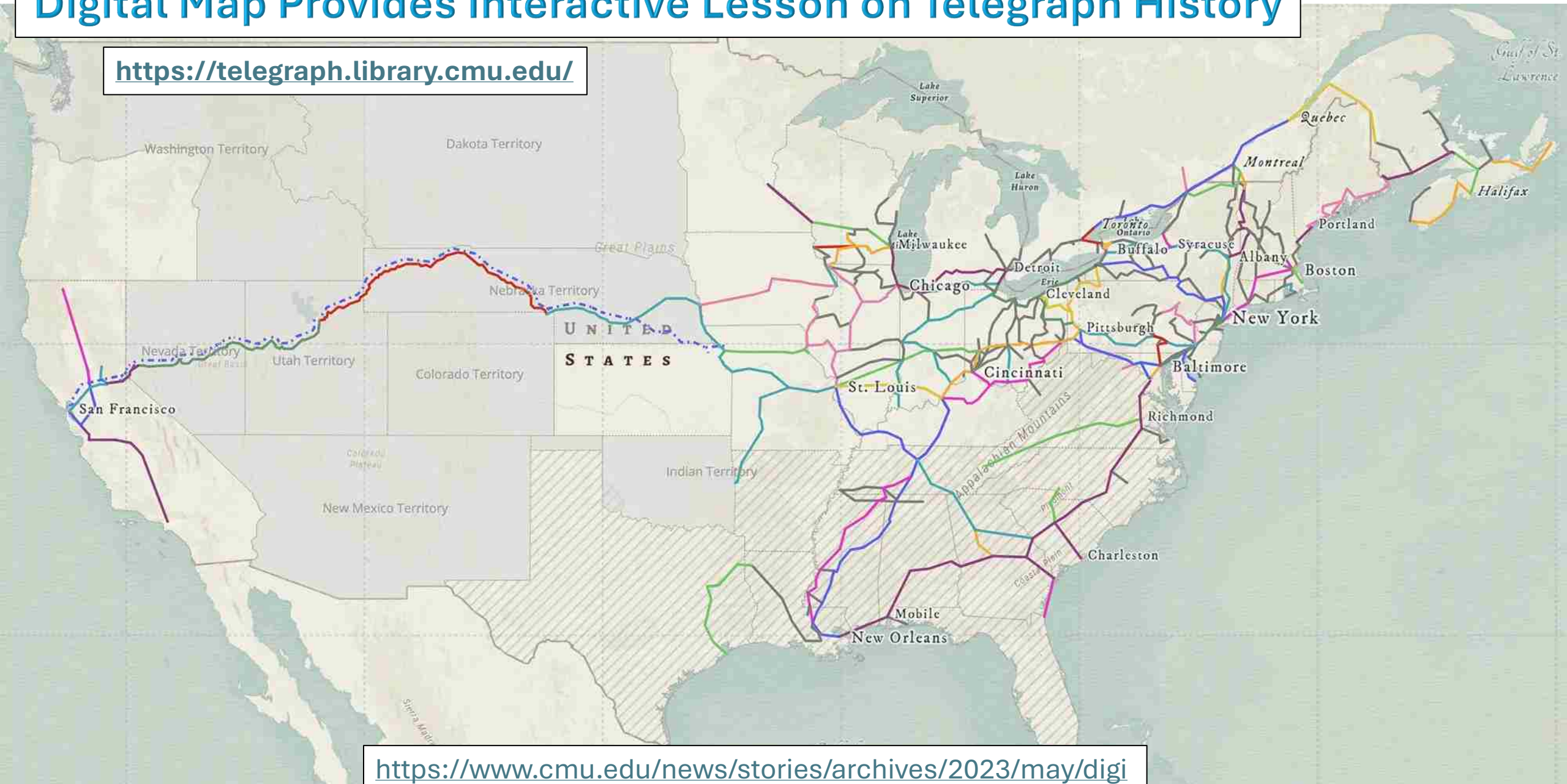

<https://www.cmu.edu/news/stories/archives/2023/may/digital-map-provides-interactive-lesson-on-telegraph-history>

Progress Overseas

- In England, most telegraph use was by the **railways**
 - In 1850 – 2,215 miles of lines – it took off in 1851
- Cooke’s telegraph was expanding in other countries
- It got off to a slow start in France because of the widespread **optical/semaphore telegraph system**
- In the US:
 - Messages were dubbed “**telegrams**”
 - Expensive – only used by the rich
- The telegraph was built-out as an unwieldy hub and spoke system
 - The Message was filled out on a form, transmitted, received and transcribed on a form and delivered by a messenger boy

More Progress

- **Thomas Edison** and **Andrew Carnegie** both started as messenger boys.
- Skilled Morse operators learned to read messages by ear.
- **Abbreviations** became common – messages were charged for by the word. *Examples:*
 - “II” (dot dot dot dot) for “I am ready”
 - “GA” (dash dash dot dot dash) for “go ahead”
 - “SFD” for “stop for dinner”
 - “GM” for “good morning”
 - 1 meant “wait a moment”
 - 2 – get answer immediately
 - 33 – “answer paid here” (prepaid response)
- Think “**LOL**” and similar initialisms today!

Form No. 1.

THE WESTERN UNION TELEGRAPH COMPANY.
INCORPORATED
21,000 OFFICES IN AMERICA. CABLE SERVICE TO ALL THE WORLD.

This Company TRANSMITS and DELIVERS messages only on conditions limiting its liability, which have been assented to by the sender of the following message. Errors can be guarded against only by repeating a message back to the sending station for comparison, and the Company will not hold itself liable for errors or delays in transmission or delivery of Unrepeated Messages, beyond the amount of tolls paid thereon, nor in any case where the claim is not presented in writing within sixty days after the message is filed with the Company for transmission.
This is an UNREPEATED MESSAGE, and is delivered by request of the sender, under the conditions named above.
THOS. T. ECKERT, President and General Manager.

NUMBER	SENT BY	REC'D BY	CHECK
13	Kpsn	15 paid	12/11

RECEIVED at **FREEHOLD, N. J.** **Sept 7** 189

Dated **New York 7**

To **E O Davis**
Freehold N.J.

Call at my house this evening after seven for the amount decided yesterday being **Bracelet**
Mrs Abreu

Many Could Not Understand the Telegraph

- ***Strange notions of what the telegraph was and how it worked persisted.***
 - Some thought **physical message slips** went through the wires
 - Some believed the wires were “**speaking tubes**”
 - A woman in Prussia took **sauerkraut to a telegraph office** to send to her son in a war (*if the telegraph could be used to “send men to war”, why not sauerkraut?*)
- The problem resulted from the new terminology:
 - **Current** - **New meaning** - flows along a wire carrying a message
 - **Current** - The **universal understanding** was a river carrying along a vessel
 - Some thought one could **hear the messages humming along the lines**
- Anecdotes of the Telegraph (*Contemporary book of thoughts on the telegraph - 1848*)

More Progress

- **October 3, 1849** – the first international telegraph was established – Prussia to Austria
 - It was Inefficient
 - A joint office was setup at the border to receive & retransmit messages
- Work on a cross-channel cable was discussed
 - Used gutta-percha for an insulator under water.
 - First try – wire was too light – it wouldn't sink, the signal was slow – **Fail!**
- One year later (**1852**) a better-quality cable was laid
 - First message was sent from London to Paris
- England to Ireland – **1853**
 - Later to Germany, Russia and Holland and other countries

Next Goal: A Trans-Atlantic Cable

- There was **skepticism** about feasibility of a **trans-Atlantic cable**
- English engineer, **Fredric N. Grisborne** had a plan for an overland telegraph line from NY to Newfoundland.
 - *Then messages would go by ship Newfoundland to/from Europe.*
 - The problem was with extending cable across such a cold climate.
 - Then he met wealthy **Cyrus W. Field** and got funding.
 - Grisborne then planned a **trans-Atlantic cable**
 - Ocean depths were investigated – **not too bad**
 - **Newfoundland to Ireland** seemed best route
 - After two 2½ years, wire had finally crossed Newfoundland
 - From New York to St. Johns

Next Goal: A Trans-Atlantic Cable

- The first Cable first went to sea in **July 1857**.
- It weighed a ton per mile and required 2 ships to carry it.
- The first 350 miles were lost at sea after a break.
- They **restarted in June 1858**.
 - The cable broke twice, and they had to start over.
 - It broke a 3rd time from a whale encounter.
 - The ships returned to Ireland for provisions.
- On **August 5, 1858** – the cable was completed between Newfoundland and Valentia Bay Ireland.
- ***Tremendous celebrations followed with lots of news stories.***

A Trans-Atlantic Cable *Fail!*

- **Queen Victoria & President Buchanan** exchanged messages.
- It took a **week** for the first message to be transmitted.
- It took **16.5 hours** to send Queen Victoria's message to President Buchanan.
- The System performed very poorly, and **the story was kept hidden**.
- Then the cable **failed totally**.
 - Some claimed the existence of a trans-Atlantic cable was a hoax.
- **After 20 years electricity was still misunderstood.**

Meanwhile ... The Telegraph and the Civil War

Critical to the Victory of the Union

- The telegraph proved its value as a tactical, operational, and strategic communication medium.
- For the first time in the history of warfare, the telegraph helped field commanders to **direct real-time battlefield operations** and permitted senior military officials to **coordinate strategy** across large distances.
 - These were key factors in the North's victory
- **15,000 miles** of cable was strung by the Union
- Much less by the Confederacy
 - Many of their telegraph operators returned
 - home to the North when the war began.



Meanwhile ... The Telegraph and the Civil War

Critical to the Victory of the Union

- From May 1, 1861, to June 30, 1865, the **USMT (US Military Telegraph)** handled some **6.5 million messages** at a total cost (for construction, repair, and operation of the network) of \$2,655,000, or about **forty-one cents per message**.
- During the war the USMT built **15,000 miles of line**, often in adverse conditions and sometimes under enemy fire.
- At its peak in 1865, the USMT network consisted of over 8,000 miles of military telegraph line and another 5,000 miles of commercial lines operated by military telegraphers.
- Of the 1,200 operators and linemen who served in the USMT, 175 were wounded or captured and 25 died in service, 8 by direct enemy action.

Back To a Trans-Atlantic Cable *Fiasco*

- **Dr. Edward Orange Wildman Whitehouse**, who had engineered the Atlantic cable, had neither practical nor theoretical experience.
 - He said to use **high voltages** with **huge electrical coils** and a **small conductor wire**.
 - **All these choices were wrong.**
 - To top it off, the cable was **poorly made**.
 - Studies were ordered to determine the reason for the failure.
 - **William Thompson**, an engineer, was called in.
 - His studies showed the **cable was too small** and **voltage was too high**, which resulted in **destroying the insulation**.
 - Also, by then, a better receiving apparatus was available.

Trans-Atlantic Cable – A New Beginning

- **Whitehouse** blamed everyone else for his failure (*sound familiar?*).
- In **1864** – a successful cable was laid from **India** to **Europe** via **the Red Sea**.
 - It employed **low voltages** and used a mirror galvanometer telegraph design.
- Money was raised for a new trans-Atlantic cable.
 - It would employ a larger core (wire) and would be more buoyant.
 - It was so heavy that only one existing ship could carry it – the **Great Eastern**
 - It was the **largest ship afloat**.
- First try at laying a new cable was begun on **June 2, 1865**.
 - It failed because of cable breakage
- They tried again beginning on **July 13, 1866**, with better equipment.
 - It landed in Newfoundland 2 weeks later.

The Great Eastern
Launched in 1858
(Largest in the World)

32,160 tons
682 feet long
14.5 knots



Operational: A Trans-Atlantic Cable

- The first day of operation earned **£1000** (\$196,000 today).
- Within a month the original broken cable was recovered, spliced and soon **2 cables** were working.
- **Cyrus W. Field** got a Congressional vote of thanks and a special gold medal.
- Cooke & Wheatstone and others were also honored.
- **Field** was honored in NY, paid off all his debts by 1867.
- Recovery and repair of broken cables became commonplace.
- The cable was expected to bring world peace.
- It was so successful it **quickly became overloaded**.

The Telegraph Became Vital

- The NY Times **4/3/1872** reported the telegraph lines were congested
- Telegrams frequently had to be routed through 2 or more lines
 - Message from **City A** to **City C** had to be routed through **City B**
 - **City B** might have had 2 or more telegraph offices serving different cities
- At intermediate offices messages piled up.
 - Messenger boys **carried bundles of messages between offices.**
 - **Pneumatic tubes** were employed to move bundles of messages between nearby offices

BY PNEUMATIC TUBE SYSTEM
FROM DISTRICT OFFICES
TO THE CENTRAL STATION

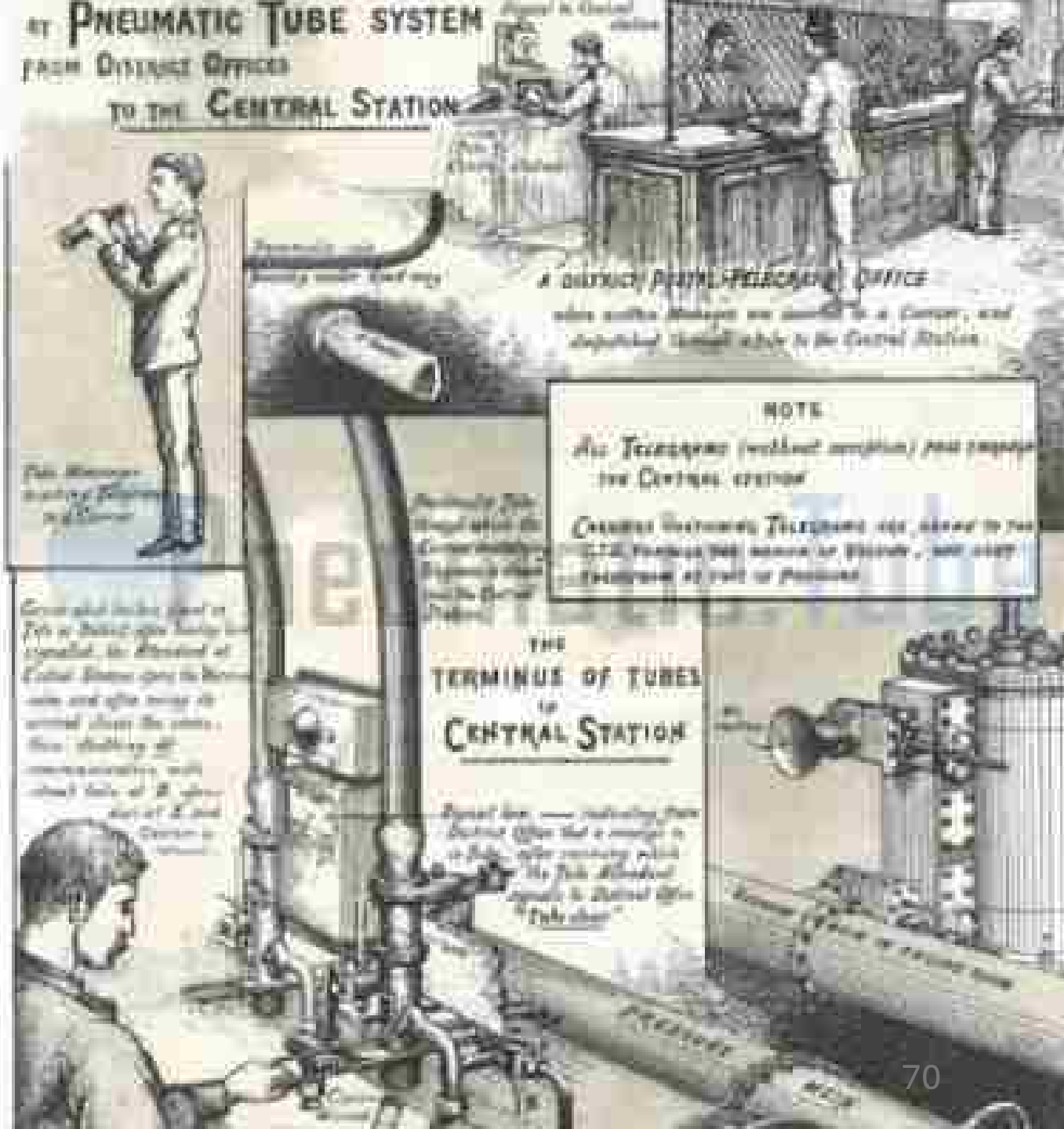

A DISTRICT POST-OFFICE
where letters, messages, and
dispatches are placed in a cylinder, and
dispatched through tubes to the Central Station.

NOTE
All Telegrams (without exception) pass through
the Central Station.
Certain important Telegrams are carried to the
Central Station by special means, and are
delivered at once to the recipient.

THE
TERMINUS OF TUBES
AT
CENTRAL STATION



General letter-carrying
by pneumatic tubes
is limited to the
Central Station only.
Messages are sent
to and from the
Central Station by
special means, and
are delivered at
once to the
recipient.



Messages are sent
to and from the
Central Station by
special means, and
are delivered at
once to the
recipient.

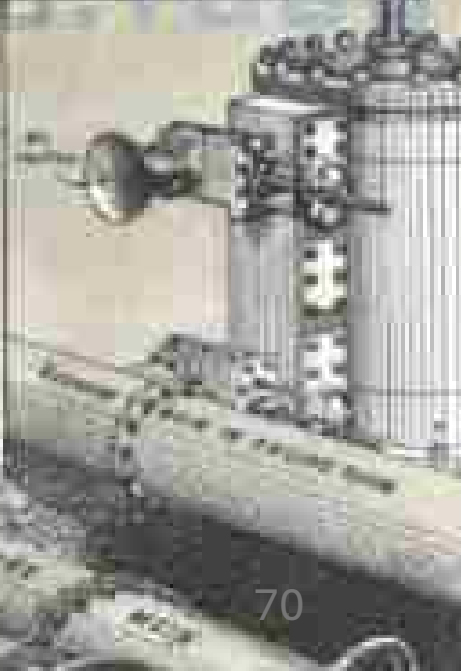

A Telegraph Dispatch Tube.

The necessity of sending telegraphic dispatches from one part of a town to another, without the loss of time occasioned by going through the busy parts on foot, has induced the post-office authorities to sanction the laying down of an experimental tube in the busiest parts of the city of London. The tube is 3 inches in diameter, and is in direct communication with the Fleet Street branch from the main office. The messages, as they arrive by the wires from the provinces or the Continent, are deciphered in the usual manner by clerks, and those intended to be delivered, say a mile from the receiving office, are then inclosed in a light cylinder.

The **Victorian Internet** was Born

- In **1844** there were a **few dozen miles of wire**.
- In **30 years**
 - **Over 650K miles of wire,**
 - **30K miles undersea,**
 - **20K towns and cities connected.**
- A message went **London to Bombay and back in ≤ 4 minutes**.
- In the **1860s** The Telegraph is booming.
- By the early 1870's – **The Victorian Internet** took shape.
- By **1880** – there were **100K miles undersea**.

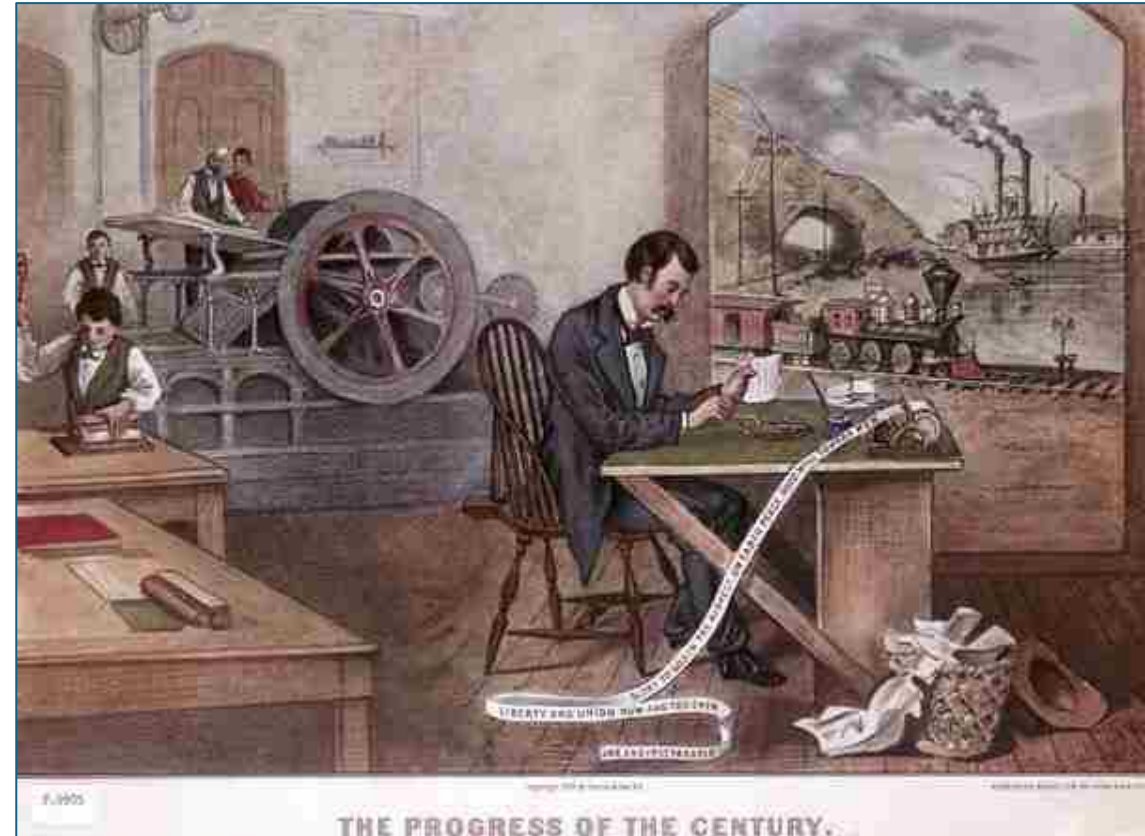

Now the Telegraph is in Operation Worldwide

- There was hope that the Telegraph would bring **World Peace** through improved communication
- Instead, opportunities for **Fraud, Theft and Deception** arose
- Need for **Codes** became evident
 - 1854 – 1 in 8 telegrams NY to New Orleans were in code
- Non-English code words, numerical codes, code books
- **1872 - Banks were concerned about Fraud and Theft**
 - Bankers developed a scheme to safely transmit \$100
 - By 1877 - \$2.5M per year transmitted via 38,669 transactions

Now the Telegraph is in Operation Worldwide

- Many attempts were made to use the Telegraph for Scams
 - Governments could intercept telegraph messages
 - [The Dreyfus Affair](#) – 05/15/1894
- **Marriages were consummated** via Telegraph
 - E.g. Boston to London
 - **Thomas Edison courted and proposed by Telegraph**
- “First class telegraph operators” became highly paid
- Newspaper reporting totally changed
 - NY Associate Press formed in **1848** (AP)
 - Paul Julius von **Reuter** in Bonn, Germany (Reuters)

Now the Telegraph is in Operation Worldwide

- **Stock Exchanges Soared**
- Gold Exchange became very important
 - **Stock and Gold “tickers”** spread widely
 - **Every Financial Office had to have one**
- **Edison** made many improvements to Stock and Gold tickers
- **Morse** was celebrated for much of telegraphy, though *he'd only invented the Key and the code.*



Now the Telegraph is in Operation Worldwide

- **Newspapers became much more profitable**
 - Telegraph allowed for **multiple editions per day**
 - **Late Breaking News** and all that!
- **By 1880** There was so much traffic that **network overload occurred.**
- **After 1886** laws were passed to make Telegraph scams illegal
- **Business of all types sped up – must use Telegraph to compete**
- **The Telegraph Industry itself became wealthy**
 - Western Union handled 80% of the traffic
 - Digests of News appeared – think **BLOGS**
 - **Sound Familiar? – sounds like Silicon Valley and the Internet**



The Telegraph Shook Up Everything

- Increased demand drove the evolution of **Automatic Telegraphy**
 - Machines that could send and receive without the need for trained operators
 - **1858** – Wheatstone patented automatic sender using **punched paper tape** – it used **Morse Code**
 - **10 times faster** than a human operator – great for **News** distribution
- Duplex, quadraplex and other new technologies allowed for multiple simultaneous messages on a single wire

The Telegraph Led Right to the Telephone

- Alexander Graham Bell worked on **Harmonic** Telegraphy
 - He heard a “twang” sound over the wire
 - Bell worked to improve this aspect of telegraphy
- Bell filed a patent for “**Improved Telegraphy**” on **February 14, 1876**
 - Patent was granted on **March 3, 1876**

The Telegraph Led Right to the Telephone

- Bell transmitted speech **one week later**
 - “Mr. Watson, come here; I want you.”
 - Morse code – could transmit **15 to 20 words per minute**
 - Telephone – **100 to 200 words per minute**
 - *No expense required for operation, maintenance or repair of a telephone*
- The **first ad for Telephone Service** appeared in **May of 1877**
- The **Telephone** was an **instant success**

The Telephone Shook Up Everything *Again!*

- **The age of the Telephone was born**
 - By the end of **June 1877** – **230** telephones
 - **July 1877** – **750** telephones
 - **August 1877** - **1800**
 - **By 1880** – **30,000** telephones world-wide
- Electrical innovations were rampant
 - **Edison** invented the **incandescent light bulb in 1879**
 - Electricity was being used for **lighting, electric trams and elevators**
- Soon the **Telegraph** *was just another use of electricity!*

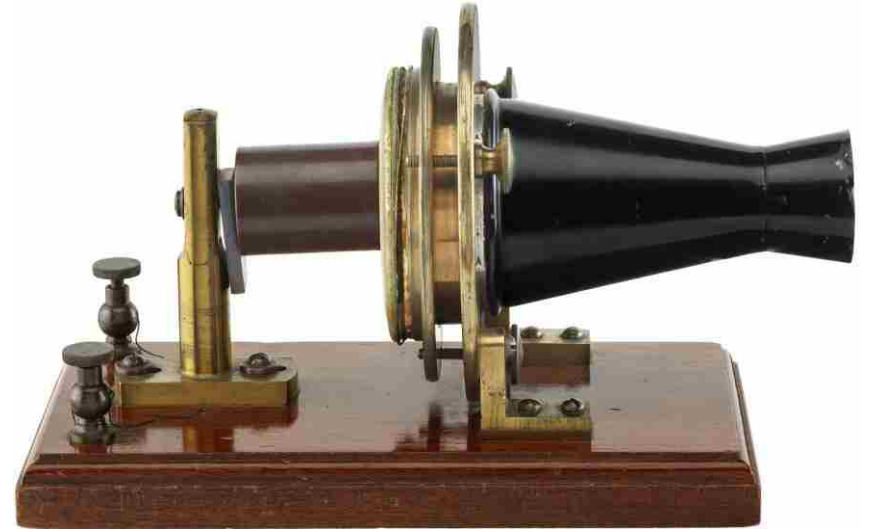

The Telephone Shook Up Everything *Again!*

- After 10 years – in **1886** – over **250,000 telephones worldwide**
 - Initial issues – sound quality, long distance, etc. – were addressed by Edison, Hughes, Watson and others
- By **1900** – nearly **2 million** phones in use
 - **1901** – a phone in **1** of every **10** homes
- 1903 the **teleprinter** (automatic telegraph system plus a keyboard)
 - Could be operated by anyone
- You know the rest ...
 - The **Fax**
 - The **Internet**, etc., etc., etc.



Teleprinter



Telephone Exchange

Then I asked a couple of AI chatbots what were the impacts of the Telegraph

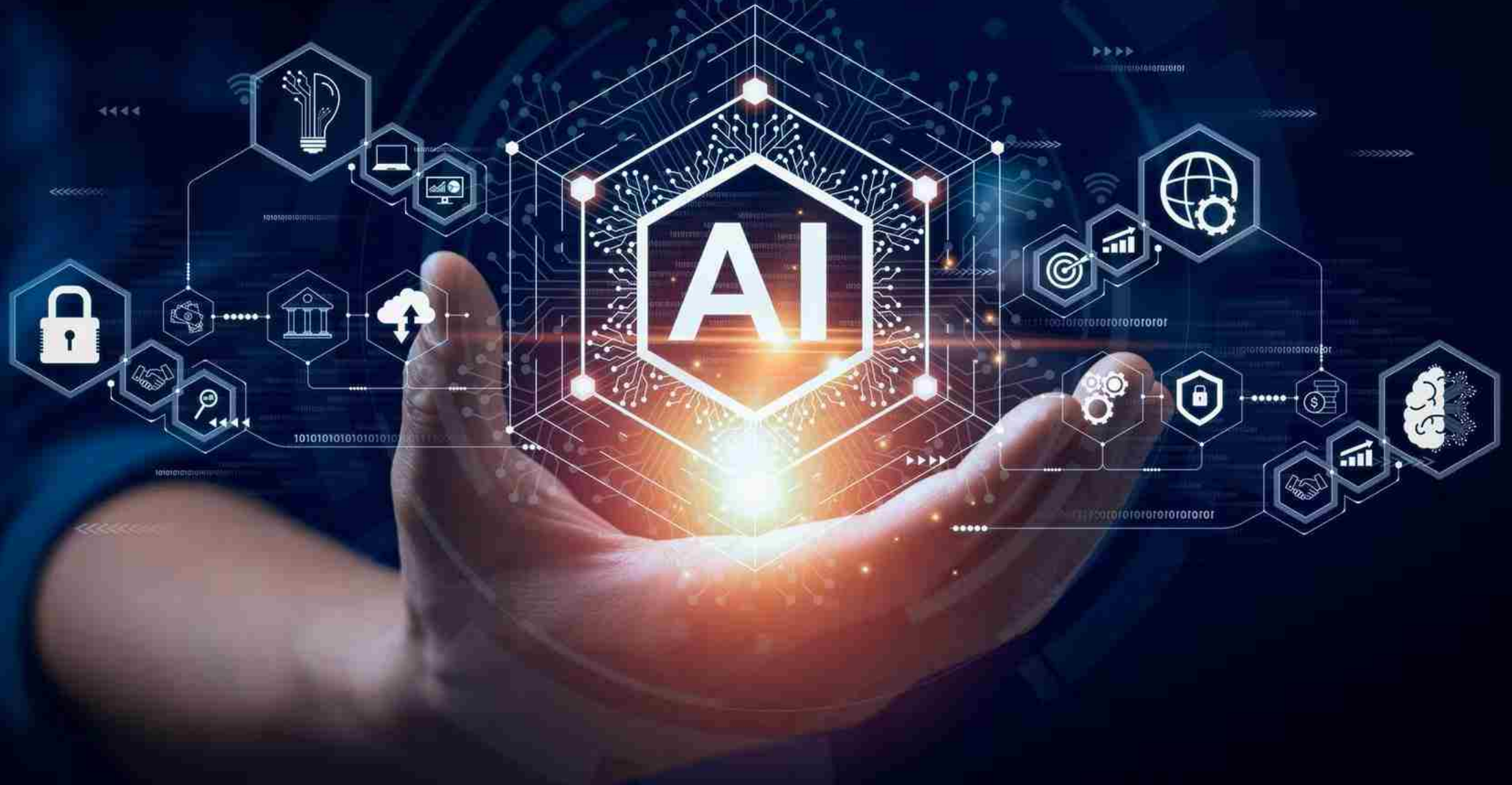

What were the Results of the Introduction of the Telegraph in the USA

- 1. Revolutionized Communication:** The telegraph drastically reduced the time it took to send messages across long distances, transforming communication from days or weeks to mere minutes¹.
- 2. Economic Growth:** It facilitated the growth of railroads by allowing for better coordination and scheduling. This, in turn, boosted trade and commerce².
- 3. Financial Markets:** The telegraph enabled the instantaneous transmission of financial data, which helped consolidate financial and commodity markets. This led to the development of early stock exchanges³

What were the Results of the Introduction of the Telegraph in the USA

4. Centralized Power: In diplomacy and governance, the telegraph centralized power by allowing leaders to make timely decisions and reducing the autonomy of distant diplomats⁴.
5. News Dissemination: Newspapers could quickly receive and publish news from distant places, leading to more informed and engaged public discourse¹.
6. Military Strategy: During the Civil War, the telegraph was crucial for coordinating troop movements and strategies, giving an advantage to those who could use it effectively

What were the Results of the Introduction of the Telegraph in the USA

7. Social Connectivity: It connected people across vast distances, fostering a sense of national unity and helping to bridge regional divides¹.

Footnotes to Results:

1. <https://www.loc.gov/collections/samuel-morse-papers/articles-and-essays/collection-highlights/impact-of-the-telegraph/>
2. <https://www.timesmojo.com/how-did-the-telegraph-impact-society/>
3. <https://www.historyoasis.com/post/telegraph-impact>
4. https://www.dailyhistory.org/How_did_the_telegraph_change_American_Diplomacy_in_the_19th_Century

Results of the Telegraph: Changes and Improvements

1. Commerce and Trade

- Faster Transactions: Businesses could conduct transactions more quickly, leading to increased efficiency and productivity¹.
- Market Expansion: Companies could expand their markets beyond local areas, reaching national and international customers¹.
- Supply Chain Management: Improved coordination and management of supply chains, reducing delays and costs¹.

2. Finance

- Stock Market: Real-time updates on stock prices and market conditions, leading to more dynamic and responsive trading².
- Banking: Enhanced communication between banks, facilitating quicker transfers and better management of financial operations².

Results of the Telegraph: Changes and Improvements

3. Technology

- Innovation: The telegraph spurred further technological advancements, including the development of the telephone and radio³.
- Infrastructure: Expansion of telegraph networks led to the development of extensive communication infrastructure³.

4. Human Communication

- Personal Communication: People could send messages over long distances quickly, making it easier to stay in touch with friends and family⁴.
- News Dissemination: News could be spread rapidly, keeping the public informed about events almost in real-time⁴.

Results of the Telegraph: Changes and Improvements

5. Personal Life

- **Social Connectivity:** Enhanced ability to maintain relationships over long distances.
- **Emergency Communication:** Faster communication in emergencies, improving response times and coordination.

¹: [Forbes](#) ²: [U-Tech Electronics](#) ³: [Riki Thompson](#) ⁴: [Forbes](#) : [U-Tech Electronics](#) : [Riki Thompson](#) : [Forbes](#) : [U-Tech Electronics](#) : [Riki Thompson](#)

Results of the Telegraph: Problems and Challenges

1. Security and Privacy

- **Interception:** Telegraph messages could be intercepted, leading to concerns about privacy and security.
- **Encryption:** The need for secure communication led to the development of encryption methods.

2. Economic Disparities

- **Access:** Not everyone had access to telegraph services, leading to disparities in communication capabilities.
- **Cost:** The cost of sending telegraph messages could be prohibitive for some individuals and businesses.

Results of the Telegraph: Problems and Challenges

3. Dependence on Technology

3. **Reliability:** Dependence on telegraph networks made communication vulnerable to disruptions due to technical failures or sabotage.
4. **Maintenance:** The need for constant maintenance and upgrades of telegraph infrastructure.

4. Social Impact

- **Information Overload:** The rapid flow of information could lead to an overload, making it difficult for individuals to process and respond to messages.
- **Cultural Changes:** The speed of communication influenced cultural norms and expectations around response times and availability.

Some References:

- How the Telegraph Worked
 - <https://www.youtube.com/watch?v=-FG1aMq2OGg>
- 9 WAYS THE TELEGRAPH IMPACTED THE WORLD
 - <https://www.historyoasis.com/post/telegraph-impact>
- When Was Electricity First Used in Homes? What You Need To Know
 - <https://housegrail.com/when-was-electricity-first-used-in-homes/>

BTW - from 1991 to now ...

1.1 BILLION
WEBSITES ON
THE INTERNET



200 MILLION
WEBSITES ARE ACTIVE

252,000
NEW WEBSITES
CREATED EVERY DAY

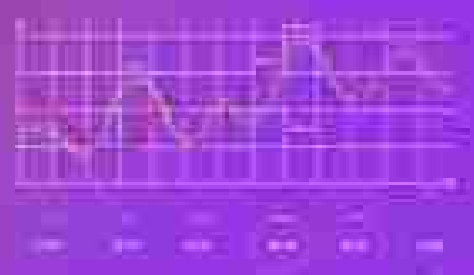

50 BILLION
WEB PAGES ARE
INDEXED ON GOOGLE

DIGITALSILK
The World's Search Engine

The Lion

